



Coimisiún na Scrúduithe Stáit State Examinations Commission

Leaving Certificate Applied - 2004

Vocational Specialism - Graphics & Construction Studies (240 marks)

Tuesday, 15th June 2004
Morning 9.30 am - 11.00 am.

For the Superintendent only

Centre Stamp

1.	Total of end of page totals	
2.	Aggregate total of all disallowed question(s)	
3.	Total mark awarded (1 minus 2)	
4.	Bonus mark for answering through Irish (if applicable)	
5.	Total mark awarded if Irish Bonus (3+4)	
Note: The mark in row 3 (or row 5 if an Irish Bonus is awarded) must equal the mark in the Mór-Iomlán box on the script		

General Directions

1. Write your examination number in this space:

--

2. There are two sections in this paper.

Section 1 - Answer **both** questions. - 105 marks

Q1 - Short answer questions

Q2 - Graphic Communication

Section 2 - Five questions, answer **any three**. - 135 marks

Q1 - Construction

Q2 - Building Services

Q3 - Woodcraft

Q4 - Design and Manufacture of Educational Toys

Q5 - Computer Aided Design

3. Write your answers in the spaces provided and include sketches as appropriate.

Section 1

**COMPULSORY
QUESTION 1**

(60 Marks)

1. Answer any TWELVE of the following FIFTEEN short questions.

(a) Sketch, in the space provided, a project you completed during the course.



(b) Describe **ONE** practical skill that you learned during the course of your practical work.

(c) Give **TWO** safety precautions to be observed when working in the Construction room:

(d) Name the **TWO** types of electrical sanders shown.

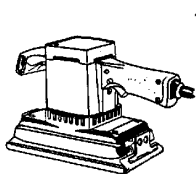

1

1

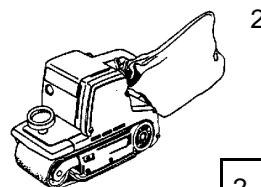

2

2

(e) Name **FIVE** tools you used during this course.

1. _____
2. _____
3. _____
4. _____
5. _____

(f) The diagram shows three bulbs wired in series. What would happen if one of the bulbs were removed?

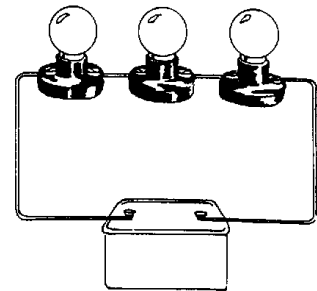

(g) Name **TWO** different types of manufactured board and briefly explain how **ONE** of the boards is manufactured.

(h) The diagram shows three standard paper sizes used in Graphics and Construction Studies. The A3 sheet size is double the A4 sheet size and the A2 sheet size is double the A3 sheet size.

Calculate the length and width of the A2 sheet.

Size: _____

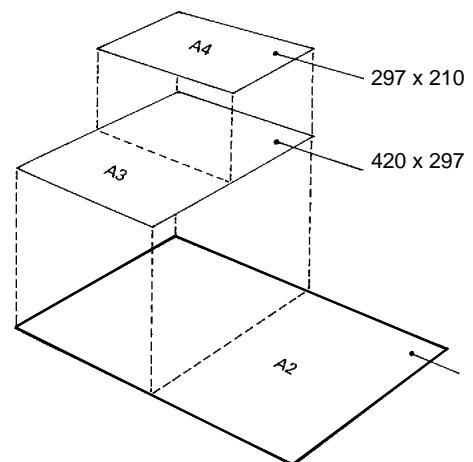

(i) The diagram shows a pictorial view of a cassette case. Sketch the plan view of the case when viewed in the direction of the arrow X.

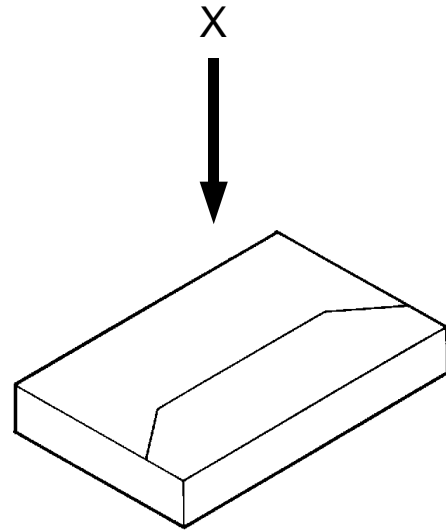

(j) Identify any **FIVE** hazards and dangerous practices shown in the picture and explain how they should be corrected.

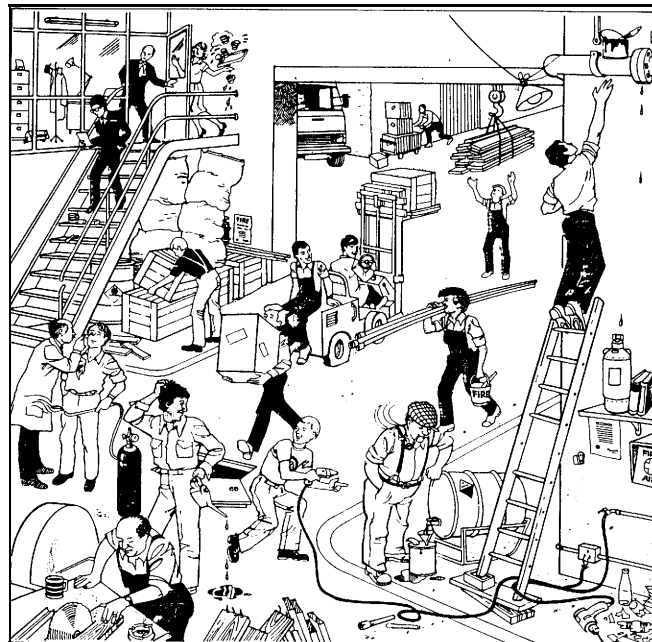

(k) Name any **TWO** of the woodwork machines shown.

- 1. _____
- 2. _____
- 3. _____

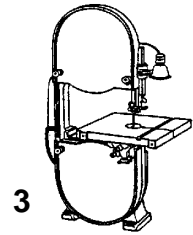
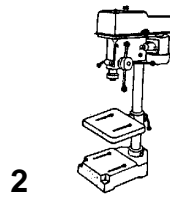
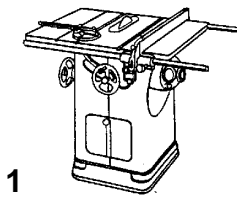

(1) A computer system with a number of peripherals is shown.
Name **THREE** input devices and **TWO** output devices.

Input devices:

Output devices:

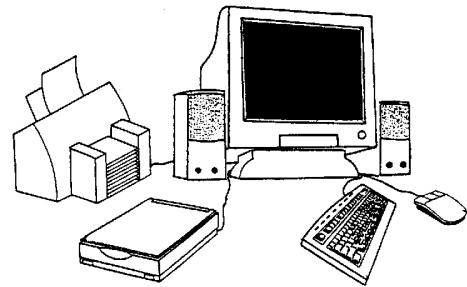

(m) The drawing shows a design for a kangaroo puzzle on a 25 mm square grid.

Calculate the size of board required to make this puzzle.

Answer: _____

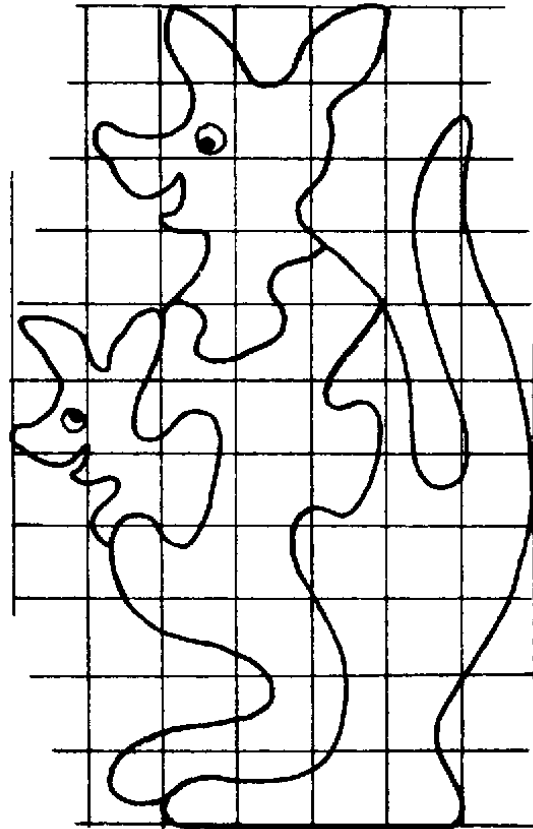

(n) Identify **ANY FIVE** of the warning signs shown below.



1



2



3



4



5



6

1. _____
2. _____
3. _____
4. _____
5. _____
6. _____

(o) Use an arrow to show the direction of rotation of wheel **X** in both drawings.

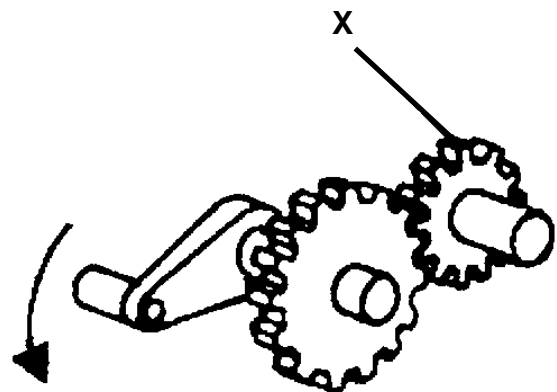
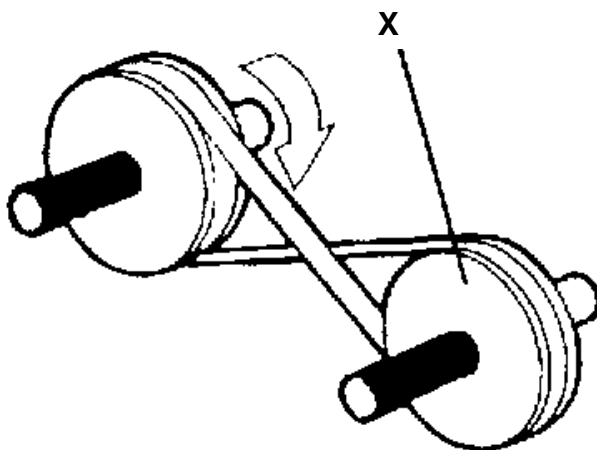

Section 1

**COMPULSORY
QUESTION 2**

(45 Marks)

2. Graphic Communication

(a) A pictorial view of a building, with dimensions, is shown on the right. The elevation, plan and end-view of the same building is shown below.

Dimension the elevation, plan and end-view, using the dimensions from the pictorial view.

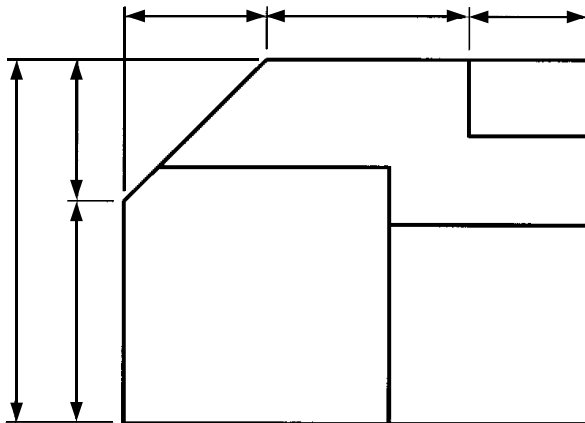
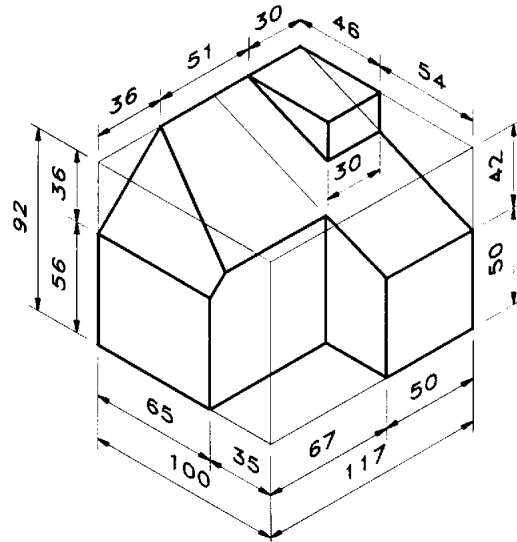

Elevation

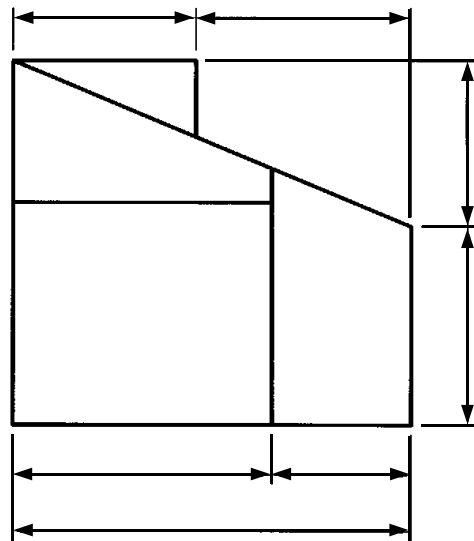

End-View

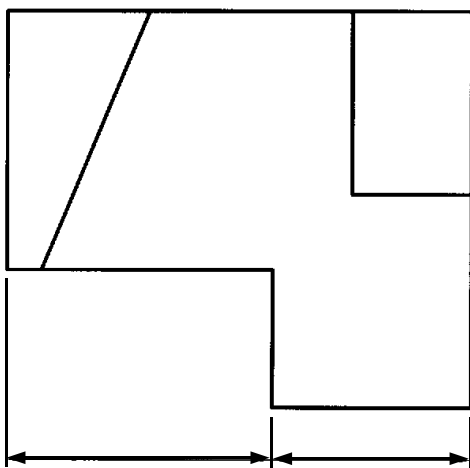

Plan



- (b) The front elevation and end elevation of a trophy are shown. Also shown is the partly complete isometric view of the trophy.

Complete the isometric view and apply appropriate shading to the isometric view.

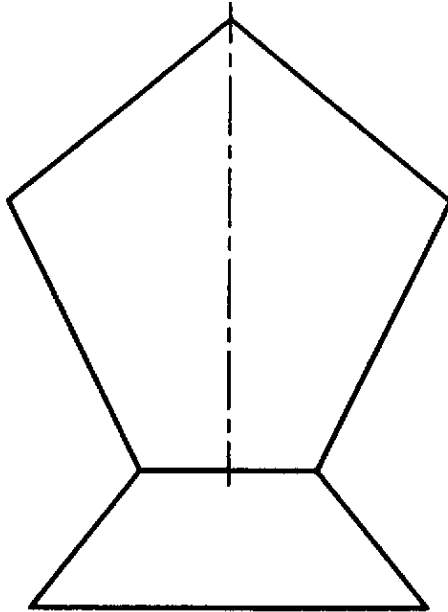

Elevation

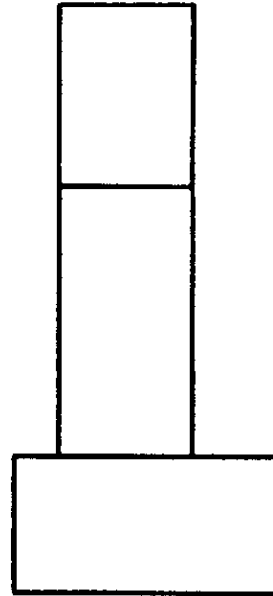

End Elevation

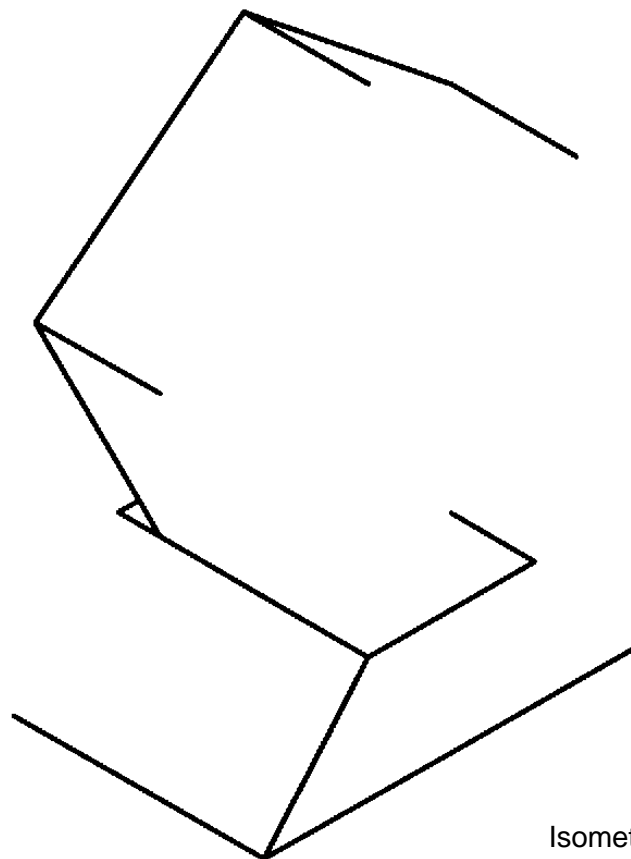

Isometric View

(c) (1) In the scale provided, show the following length: **4.2 m**

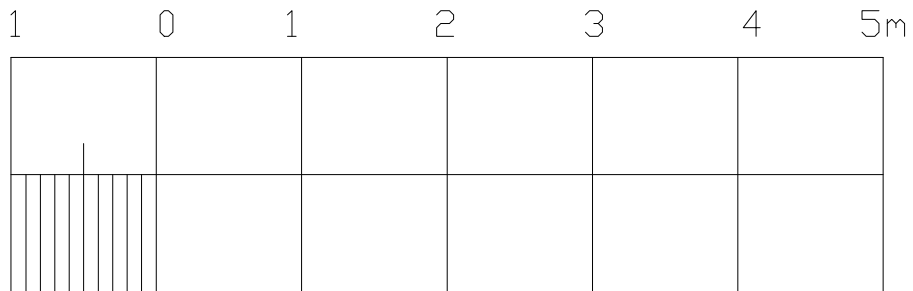

(c) (2) Determine the area of the irregular figure in square units.
1 square = 1 x 1 units

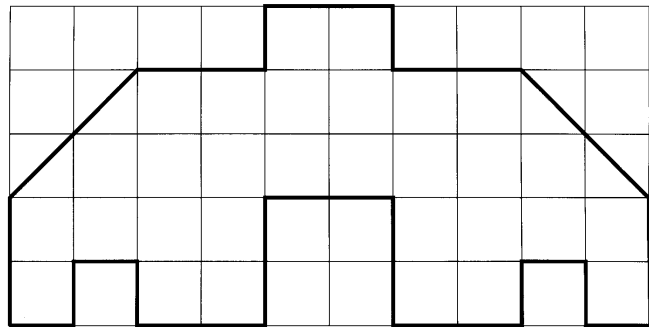

Answer: _____

(c) (3) The figure shown on the left is to be enlarged to twice its original size.
Draw the figure twice full size on the enlarged grid.

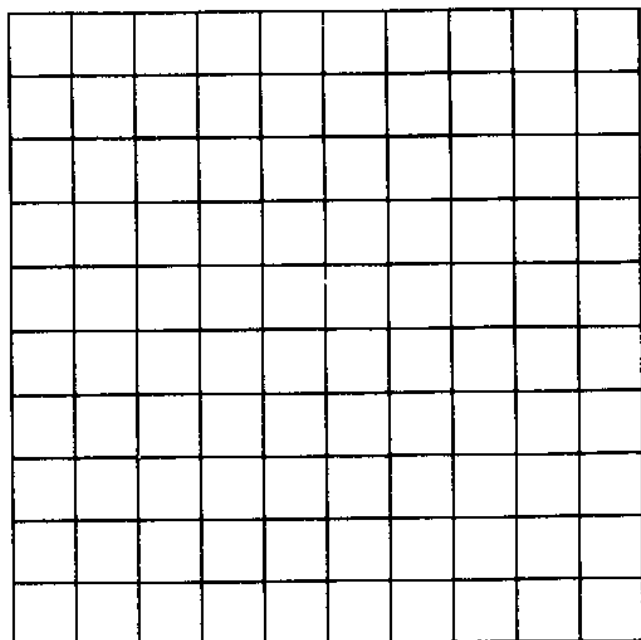
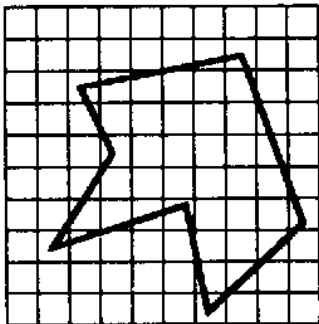

Section 2

(135 Marks)

Answer **ANY THREE** Questions from this section.

1. Construction

(a) (1) Give **ONE** reason to explain why it is necessary to control planning permission.

(a) (2) Name **THREE** types of planning permission.

(i) _____

(ii) _____

(iii) _____

(b) A typical concrete ground floor detail, including a cavity wall, is shown below.

Name any **FIVE** of the parts shown.

1. _____
2. _____
3. _____
4. _____
5. _____
6. _____
7. _____

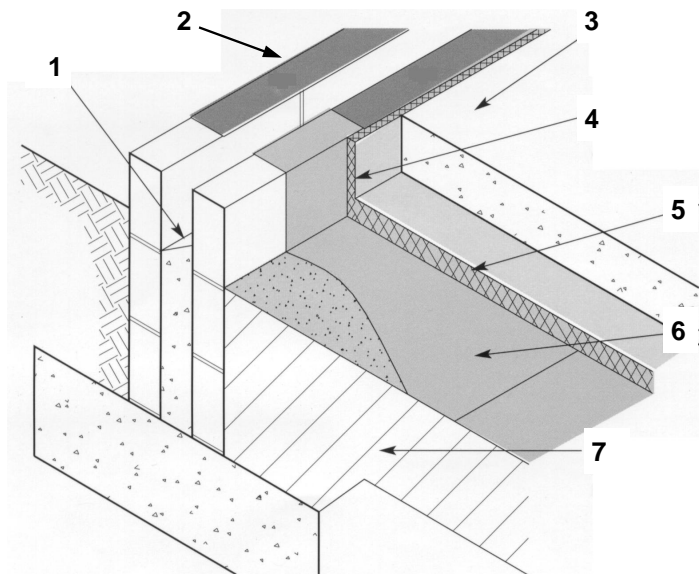

(c) The diagram shows a typical detail for a stud partition.

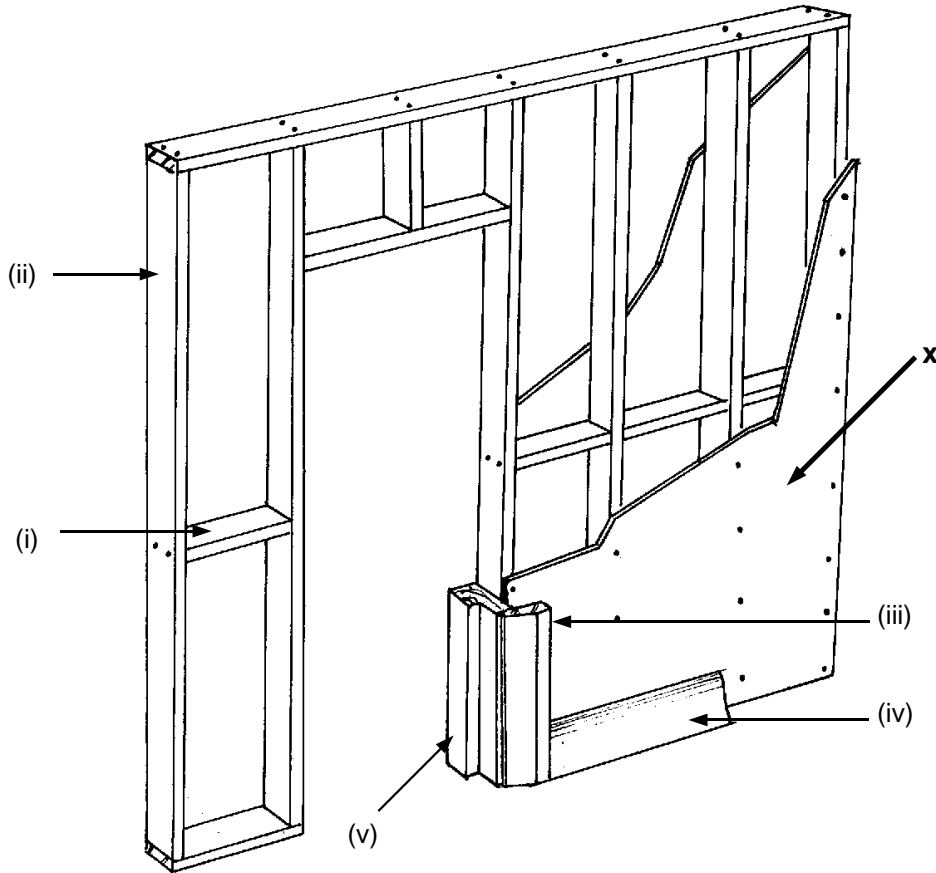

(c) (1) Name any **THREE** of the labelled parts.

- (i) _____ (ii) _____
 (iii) _____ (iv) _____
 (v) _____

(c) (2) Name the type of board generally fixed to the stud at position **X**.

(c) (3) List **ONE** advantage and **ONE** disadvantage of this board material.

Advantage: _____

Disadvantage: _____

2. Building Services

- (a) The diagram shows the indirect hot and cold water system.

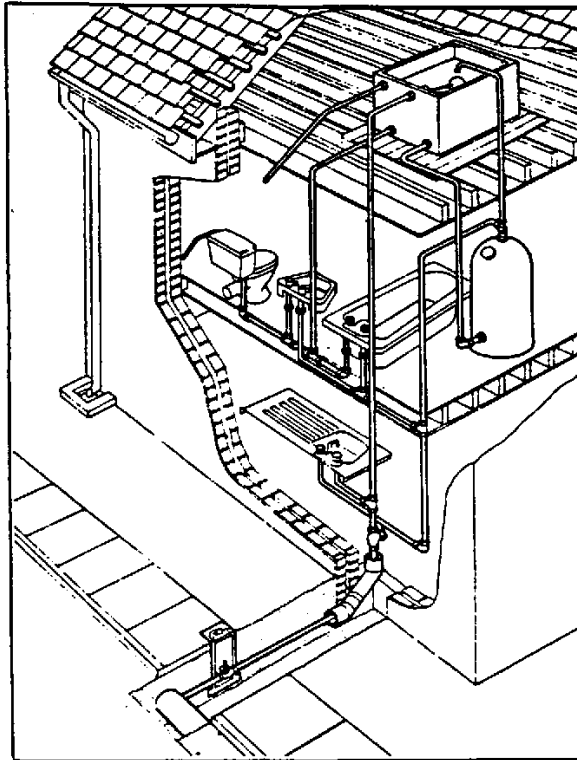

- (a) (1) Explain, briefly, how the **indirect cold water system** works.

- (a) (2) Give **TWO** advantages of the indirect cold water system.

- (a) (3) Explain why the cold tap at the kitchen sink is directly connected to the mains.

(b) (1) Name **THREE** energy sources used in the generation of electricity.

1. _____

2. _____

3. _____

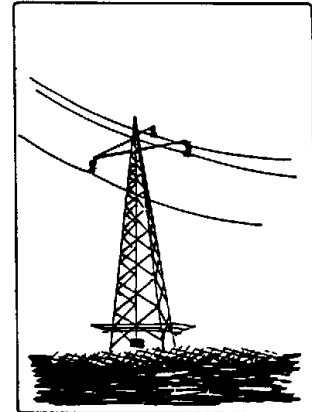

(b) (2) Give **ONE** reason to explain why overhead power lines are used to distribute electricity from generating stations.

(c) (1) Sketch a plug top in the space provided.
(2) Name the **THREE** terminals on your sketch.



3. Woodcraft

- (a) A sketch of a birdhouse is shown opposite.
 (1) Outline **THREE** factors that should be considered when designing a birdhouse.

1. _____
2. _____
3. _____

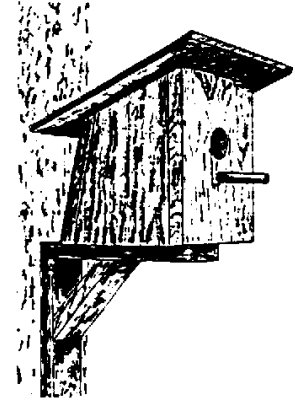

- (a) (2) Sketch **ONE** change you would make to the design of the birdhouse.



- (b) Identify any **FIVE** of the following fittings.

1. _____
2. _____
3. _____
4. _____
5. _____
6. _____

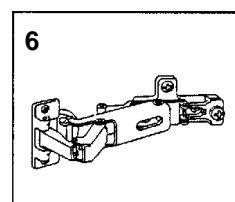
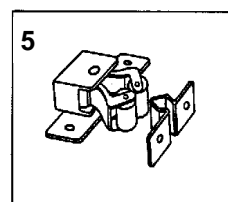
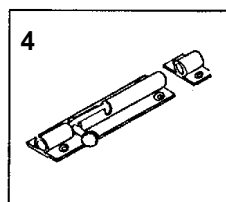
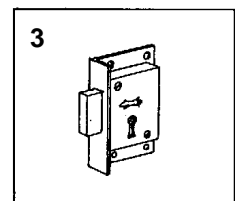
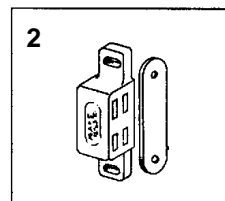
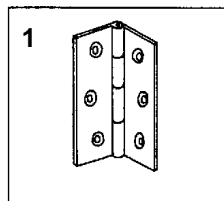

- (c) The drawing shows a small book rack.
(c) (1) Suggest a suitable hardwood for this project.

- (c) (2) Suggest a suitable joint to join the rails to the sides.

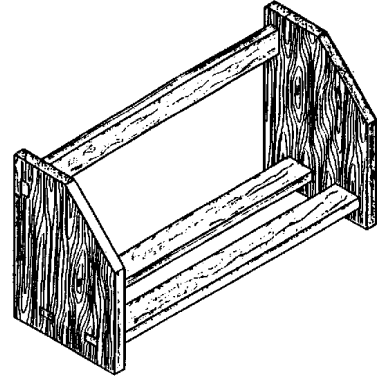

- (c) (3) Sketch, in the space provided, an alternative design for the sides of the book rack.



4. Design and Manufacture of Educational Toys

- (a) A pull-along toy, 'Willy the Whale', is shown. The toy has an interesting movement for a child in which the front moves up and down as the toy is pulled along. Sketch, in the space below, a method you would use to make the toy move up and down.

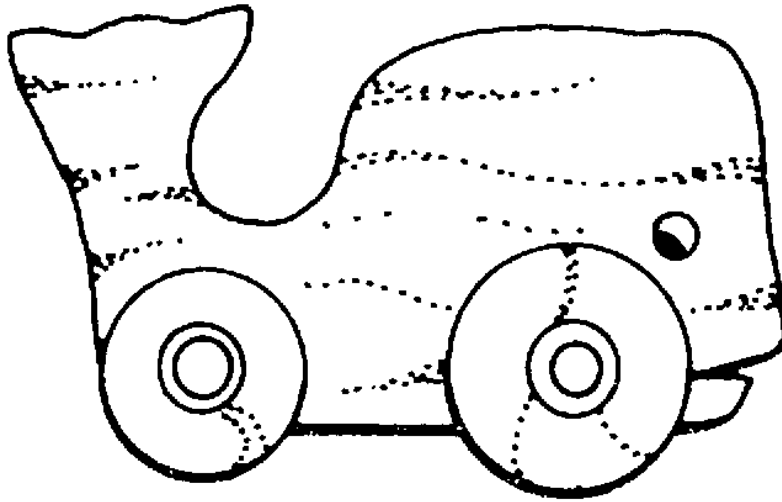

(b) (1) List **THREE** safety features that should be considered when buying a child's toy.

(i) _____

(ii) _____

(iii) _____

(b) (2) Give **TWO** reasons why wood is a suitable material for toy making.

(i) _____

(ii) _____

(c) A simple stand-up puzzle made from solid wood is shown.

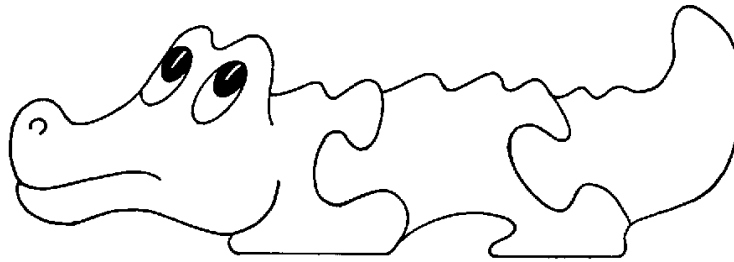

(c) (1) Explain how you would transfer the puzzle pattern onto a piece of wood.

(c) (2) Name an appropriate tool or machine that might be used to cut-out the puzzle.

(c) (3) Describe how you would finish this toy and make it safe for children.

5. Computer Aided Design

- (a) The drawing shown was created using a CAD package.
List the relative co-ordinates for points 1—5.

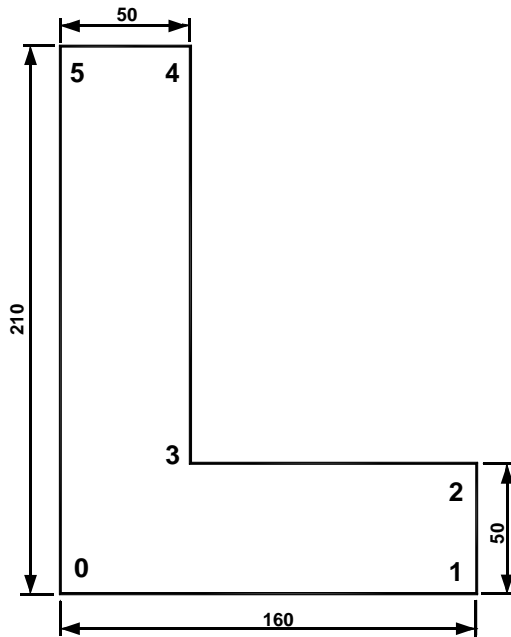

1.

2.

3.

4.

5.

- (b) A CAD design for a garden wall is shown below.

- (1) Name **THREE** CAD commands required to draw the design shown.

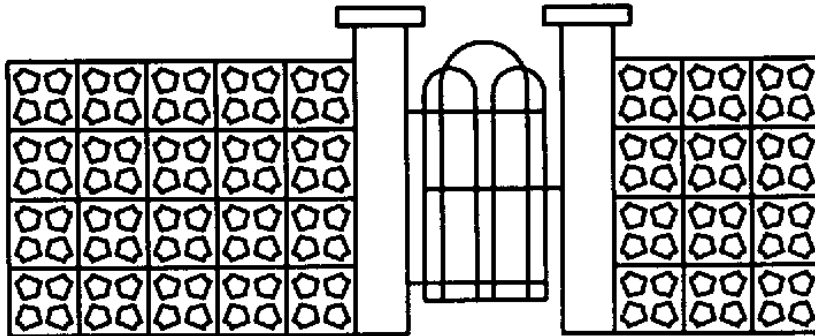

1.





2.

3.

- (b) (2) Describe using CAD how you would create the wall design shown above.

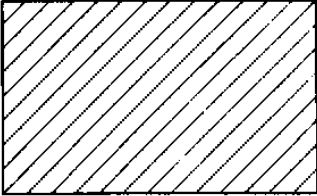

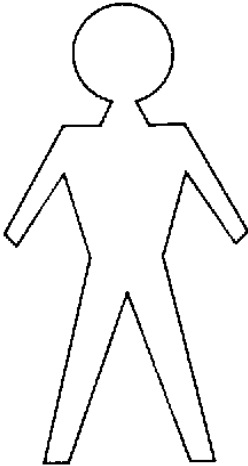
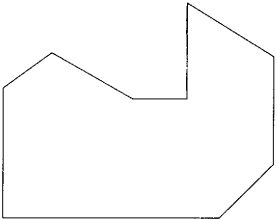
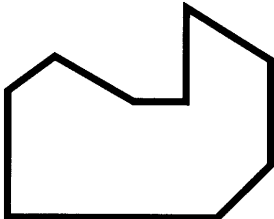
(c) Identify the CAD commands required to produce the modified drawing from the original drawing.

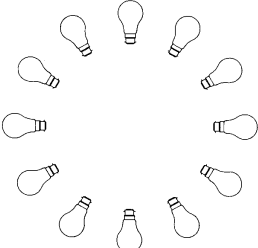
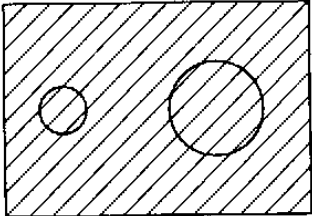
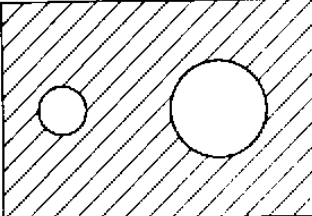
ORIGINAL	MODIFIED	COMMAND
		
		
		
		
		

For Examiner's use only

	Marks Awarded
Section 1 Q1	
Section 1 Q2	
Section 2 Q1	
Section 2 Q2	
Section 2 Q3	
Section 2 Q4	
Section 2 Q5	
Total	