



**Coimisiún na Scrúduithe Stáit**  
**State Examinations Commission**

**Junior Certificate 2014**

**Marking Scheme**

**Technical Graphics**

**Ordinary Level**

## **Note to teachers and students on the use of published marking schemes**

Marking schemes published by the State Examinations Commission are not intended to be standalone documents. They are an essential resource for examiners who receive training in the correct interpretation and application of the scheme. This training involves, among other things, marking samples of student work and discussing the marks awarded, so as to clarify the correct application of the scheme. The work of examiners is subsequently monitored by Advising Examiners to ensure consistent and accurate application of the marking scheme. This process is overseen by the Chief Examiner, usually assisted by a Chief Advising Examiner. The Chief Examiner is the final authority regarding whether or not the marking scheme has been correctly applied to any piece of candidate work.

Marking schemes are working documents. While a draft marking scheme is prepared in advance of the examination, the scheme is not finalised until examiners have applied it to candidates' work and the feedback from all examiners has been collated and considered in light of the full range of responses of candidates, the overall level of difficulty of the examination and the need to maintain consistency in standards from year to year. This published document contains the finalised scheme, as it was applied to all candidates' work.

In the case of marking schemes that include model solutions or answers, it should be noted that these are not intended to be exhaustive. Variations and alternatives may also be acceptable. Examiners must consider all answers on their merits, and will have consulted with their Advising Examiners when in doubt.

## **Future Marking Schemes**

Assumptions about future marking schemes on the basis of past schemes should be avoided. While the underlying assessment principles remain the same, the details of the marking of a particular type of question may change in the context of the contribution of that question to the overall examination in a given year. The Chief Examiner in any given year has the responsibility to determine how best to ensure the fair and accurate assessment of candidates' work and to ensure consistency in the standard of the assessment from year to year. Accordingly, aspects of the structure, detail and application of the marking scheme for a particular examination are subject to change from one year to the next without notice.



***Junior Certificate Examination, 2014***

***Technical Graphics***  
***Ordinary Level***

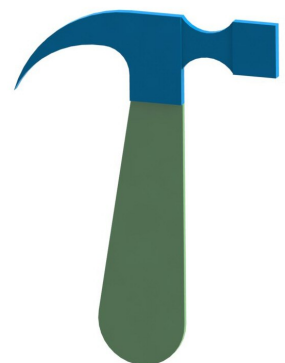
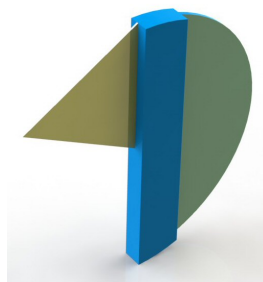
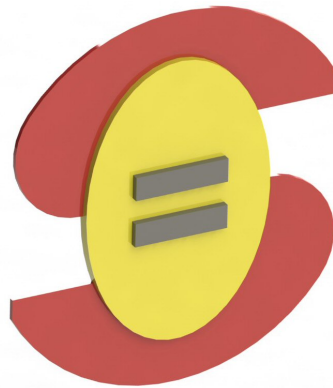
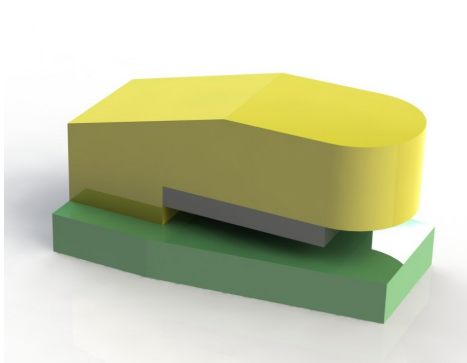

***Marking Scheme***  
***Sections A and B***

## Section A - Any ten questions from this section.

The descriptions, methods and definitions in the scheme are not exhaustive and alternative valid answers are acceptable. If you are unsure of the validity of an alternative answer, contact your advising examiner.

|                  |                  |   |
|------------------|------------------|---|
| <b>Q1</b>        | 4<br>8           | Project lines from Elevation ( <b>2 x 2 marks</b> )<br>End Elevation – 4 lines – ( <b>4 x 2 marks</b> ) (-1 mark if hidden detail not shown)  |
| <b>Q2</b>        | 8<br>4           | For a good quality, well proportioned freehand pictorial sketch ( <b>5 marks for average quality or rule used</b> )<br>For colour or shading  |
| <b>Q3</b>        | 6<br>6           | 1 Advantage<br>1 Disadvantage   |
| <b>Q4</b>        | 2<br>3<br>3<br>4 | Horizontal & Vertical lines from centre – 2 lines ( <b>2 x 1 mark</b> )<br>Draw large circle ( <b>3 marks</b> )<br>Draw inner circle ( <b>3 marks</b> )<br>Completion of logo ( <b>4 x 1 mark</b> ) |
| <b>Q5</b>        | 4<br>2<br>6      | Correct location of F and F1 ( <b>2 x 2 marks</b> )<br>Bisection of angle for tangent ( <b>2 marks</b> )<br>Drawing line PL, horizontal and vertical lines ( <b>3 x 2 marks</b> )                   |
| <b>Q6</b>        | 8<br>4           | 1 mark per line ( <b>8 x 1 mark</b> ) (-3 if rule used)<br>For colour or shading  |
| <b>Q7</b>        | 12               | 31 – 33 sq. units = <b>12 marks</b><br>( <b>30 or 34 = 6 marks</b> )  |
| <b>Q8</b>        | 6<br>6           | A = 160 ( <b>6 marks</b> )<br>B = 100 ( <b>6 marks</b> )  |
| <b>Q9</b>        | 9<br>3           | Elevation of blocks – 3 rows ( <b>3 x 3 marks</b> )<br>3 marks for each correct row (-1 mark each row incorrect)<br>Good proportion   |
| <b>Q10</b>       | 6<br>6           | Join centres ( <b>2 x 2 marks</b> ) Draw normal ( <b>2 marks</b> )<br>Location of 3 points of contact ( <b>3 x 2 marks</b> )  |
| <b>Q11</b>       | 12               | Any two commands ( <b>2 x 6 marks</b> )<br>(Circle, Trim, Extrude boss/base, line, rectangle)   |
| <b>Q12</b>       | 4<br>8           | 1 mark for each projection line to plan<br>Complete 4 lines in plan ( <b>4 x 2 marks</b> )  |
| <b>Q13</b>       | 9<br>3           | Complete semi-hexagon – 3 lines – 3 marks per line ( <b>3 x 3 marks</b> )<br>For colour or shading  |
| <b>Q14</b>       | 12               | 6 lines – 2 marks per line ( <b>6 x 2 marks</b> )   |
| <b>Q15</b>       | 3<br>6<br>3      | 3 Vertical lines ( <b>3 x 1 mark</b> )<br>2 sloping lines ( <b>2 x 2 marks</b> ), circle ( <b>2 marks</b> )<br>For colour or shading  |
| <b>Total 120</b> |                  |   |

**Section B** – Any **four** questions from this section  
**Q1: Orthographic Projection**

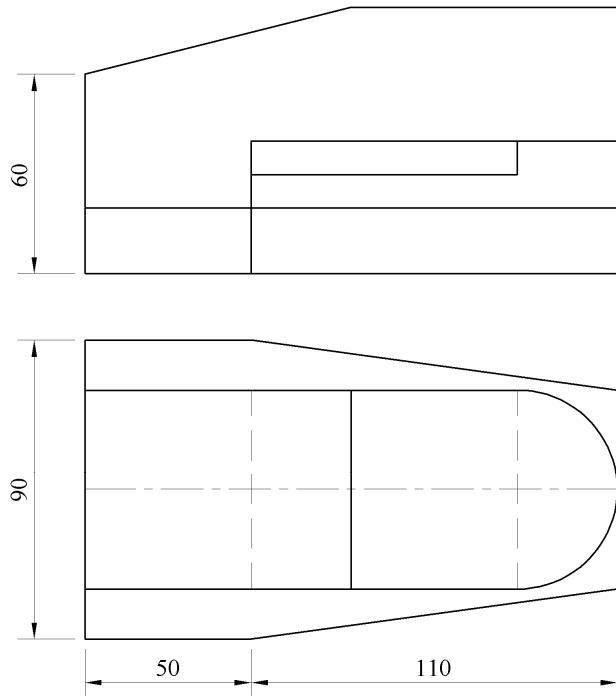
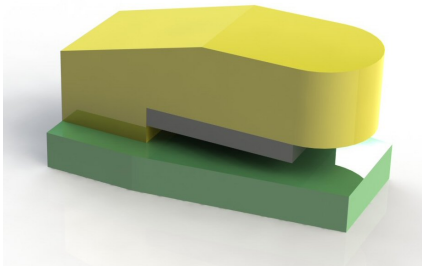

|                                  |  |
|----------------------------------|--|
| <b>Orthographic Outline (10)</b> |  |
| 10                               | Elevation and Plan positioned correctly<br>(4 marks incorrect position of views, 1 view = 3 marks) |
| <b>Elevation (22)</b>            |  |
| 10                               | 5 horizontal lines – (5 x 2 marks)   |
| 10                               | 5 vertical lines – (5 x 2 marks)   |
| 2                                | Top sloped surface – 2 marks   |
| <b>Plan (22)</b>                 |  |
| 8                                | Base outline – 4 lines (4 x 1 mark) 2 sloping lines (2 x 2 marks)                                  |
| 6                                | Top – 3 lines (3 x 2 marks)  |
| 4                                | Semi-circle - 4 marks  |
| 4                                | Hidden detail – 2 lines (2 x 2 marks)  |
|                                  |  |
| <b>Dimension lines (4)</b>       |  |
| 4                                | 1 mark per dimension (4 x 1 mark)  |
| (12)                             | Drafting, accuracy and presentation  |
| <b>Total 70</b>                  |  |

## Q 2: Ellipse

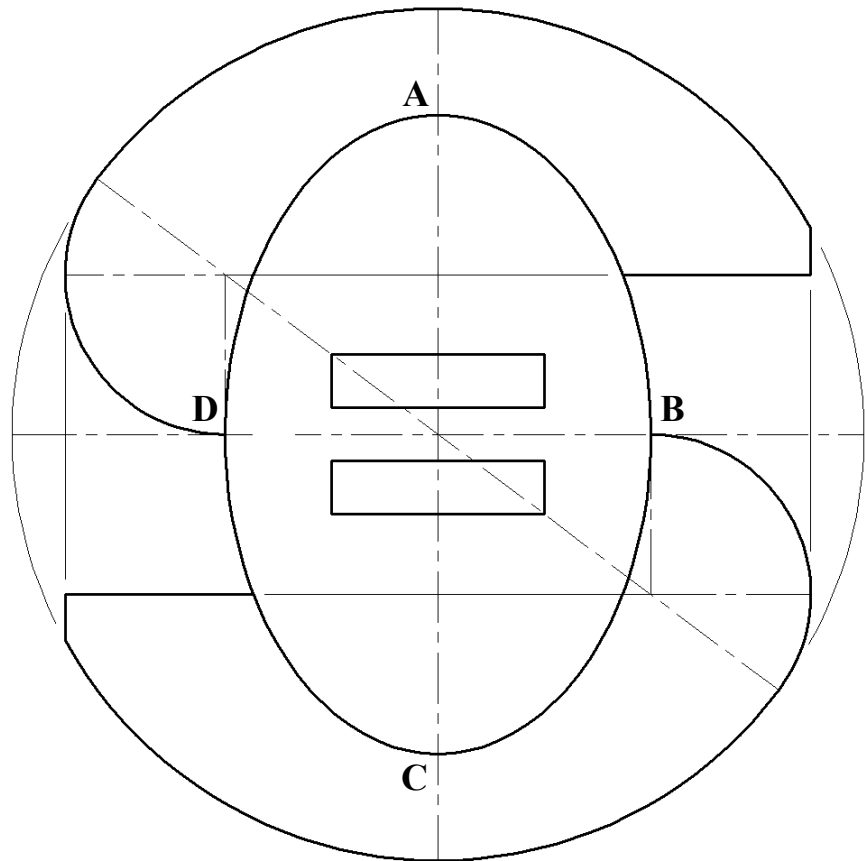
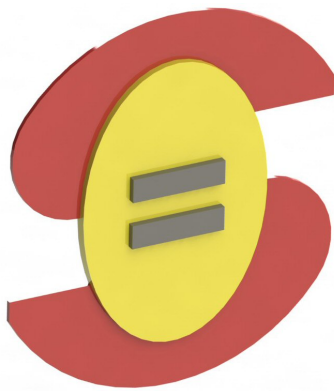

|                        |  |
|------------------------|--|
| <b>Rugby Ball (34)</b> |  |
| 8                      | Ellipse; Major AC; minor DB – (2x4 marks)                            |
| 10                     | Construction for ellipse ( <b>incorrect application = 4 marks</b> )  |
| 8                      | Drawing curve of ellipse ABCD ( <b>8,6,4, depending on quality</b> ) |
| 8                      | Stitching – 8 lines ( <b>8 x 1 marks</b> )                           |
| <b>Figure S (24)</b>   |  |
| 5                      | Circle – R80 ( <b>5 marks</b> )                                      |
| 9                      | Offsets 30 ( <b>2 x 3 marks</b> ) Diagonal line ( <b>3 marks</b> )   |
| 6                      | Arcs – R30 ( <b>2 x 3 marks</b> )                                    |
| 4                      | Complete Logo – 4 lines ( <b>4 x 1 mark</b> )                        |
|                        |  |
| (12)                   | Drafting, accuracy and presentation                                  |
| <b>Total 70</b>        |  |

### Q 3: Surface Development

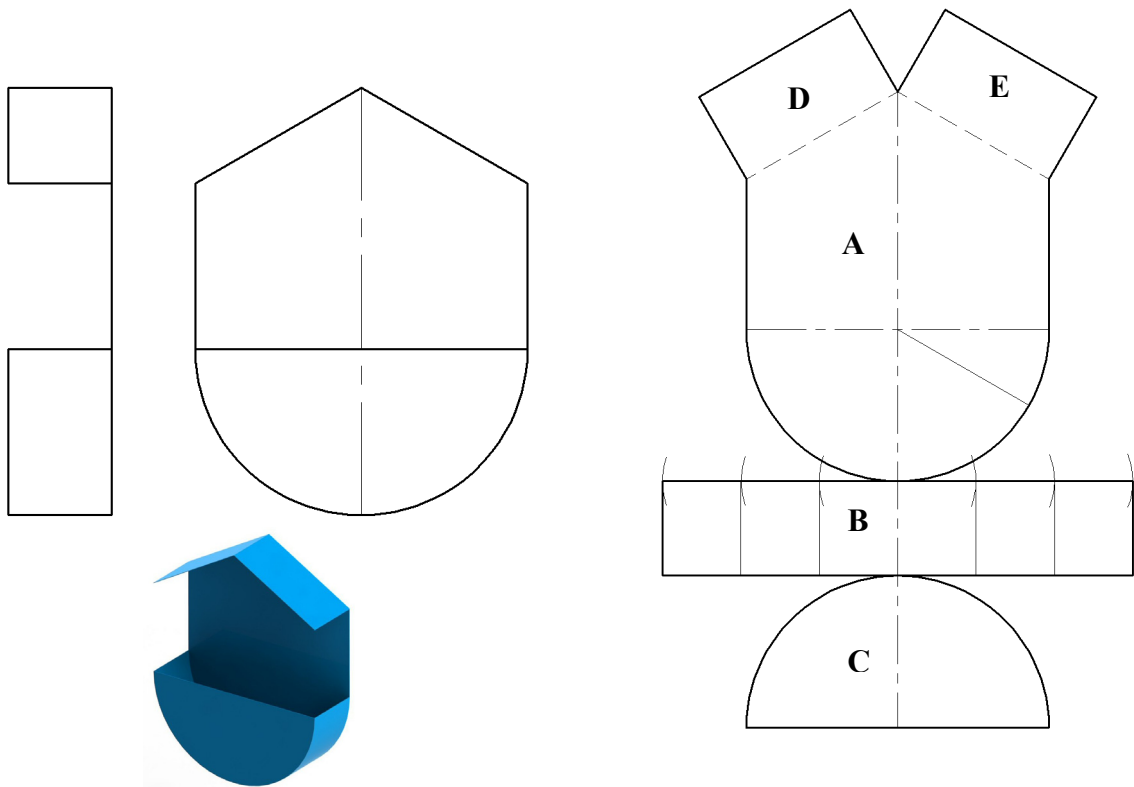

|                          |   |
|--------------------------|---|
| <b>Orthographic (21)</b> |   |
| 4                        | Elevation and End Elevation in correct position<br><b>(End elevation in wrong location or 1 view = 2 marks)</b>   |
| 10                       | Elevation: Semi-circle - <b>3 marks</b> - 3 lines ( <b>3 x 1 mark</b> )<br>2 sloping lines ( <b>2 x 2 marks</b> ) |
| 7                        | End Elevation: 7 lines ( <b>7 x 1 marks</b> )   |
| <b>Development (37)</b>  |   |
| 12                       | Back <b>A</b> – 4 lines and semi-circle ( <b>4 x 2 marks + 4 marks</b> )  |
| 4                        | Construction for finding correct length of side <b>B</b> ( <b>4 marks</b> )                                       |
| 4                        | Side <b>B</b> – 4 lines ( <b>4 x 1 marks</b> )  |
| 3                        | Side <b>C</b> – semi-circle and line ( <b>2 + 1 marks</b> )   |
| 6                        | Side <b>D</b> – 3 lines ( <b>3 x 2 marks</b> )  |
| 6                        | Side <b>E</b> – 3 lines ( <b>2 x 2 marks</b> )  |
| 2                        | Fold lines ( <b>2 x 1 mark</b> )  |
| (12)                     | Drafting, accuracy and presentation   |
| <b>Total 70</b>          |   |

## Q 4: Isometric Projection

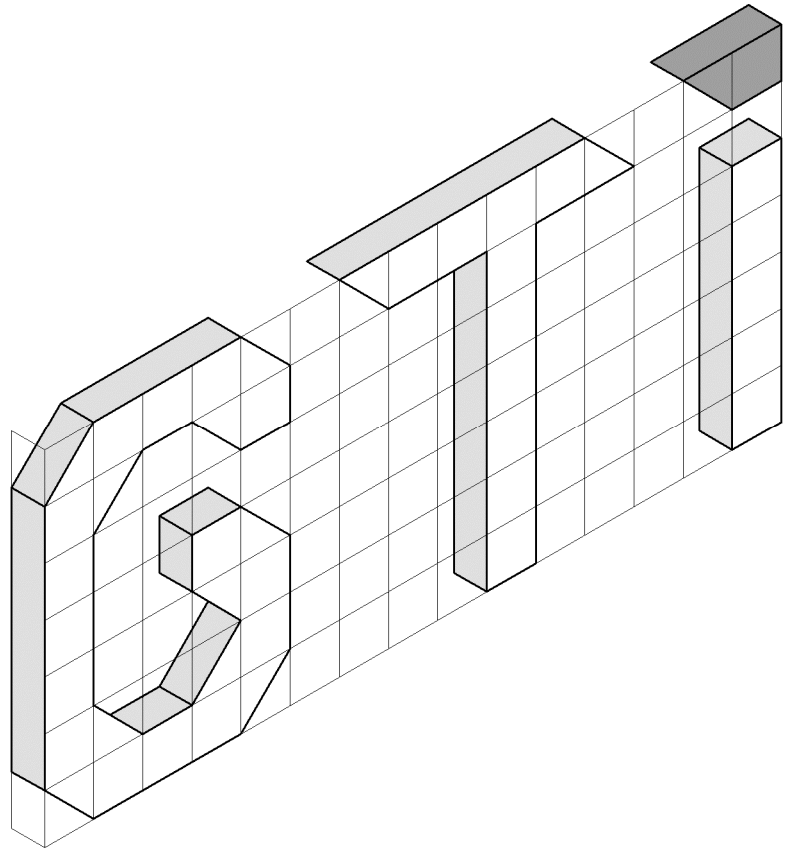

|                            |   |
|----------------------------|---|
| <b>Setting Up (13)</b>     |   |
| 9                          | Height, length and width of grid ( <b>3x3 marks</b> )<br><i>(deduct 2 each if inaccurate)</i> |
| 4                          | Isometric outline <i>(deduct 2 + 2 marks if 30° angles are not used)</i>                      |
|                            |   |
| <b>Front Face (27)</b>     |   |
| 11                         | Letter <b>G</b> – 21 lines – (Half mark each line)  |
| 8                          | Letter <b>T</b> – 8 lines ( <b>8x1 mark</b> )   |
| 8                          | Letter <b>i</b> - 8 lines ( <b>8x1 mark</b> )   |
|                            |   |
| <b>Complete width (18)</b> | 6 marks per letter ( <b>3 marks per letter if all lines are not put in</b> )                  |
|                            |   |
| (12)                       | Drafting, accuracy and presentation   |
| <b>Total 70</b>            |   |



### Q 4: Oblique Projection

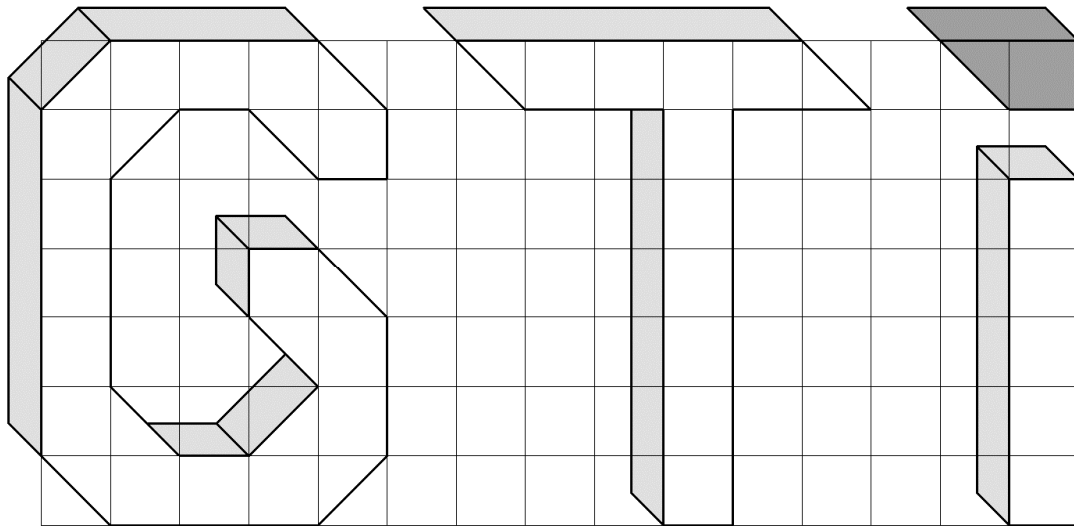

|                            |   |
|----------------------------|---|
| <b>Setting Up (13)</b>     |   |
| 9                          | Height, length and width of grid ( <b>3×3 marks</b> )<br><i>(deduct 2 each if inaccurate)</i> |
| 4                          | Oblique outline <i>(deduct 4marks if 45° angle not used)</i>                                  |
|                            |   |
| <b>Front Face (27)</b>     |   |
| 11                         | Letter <b>G</b> – 21 lines – (Half mark each line)  |
| 8                          | Letter <b>T</b> – 8 lines ( <b>8×1 mark</b> )   |
| 8                          | Letter <b>i</b> - 8 lines ( <b>8×1 mark</b> )   |
|                            |   |
| <b>Complete width (18)</b> | 6 marks per letter ( <b>3 marks per letter if all lines are not put in</b> )                  |
|                            |   |
| (12)                       | Drafting, accuracy and presentation   |
| <b>Total 70</b>            |   |

## Q 5: Transformation Geometry

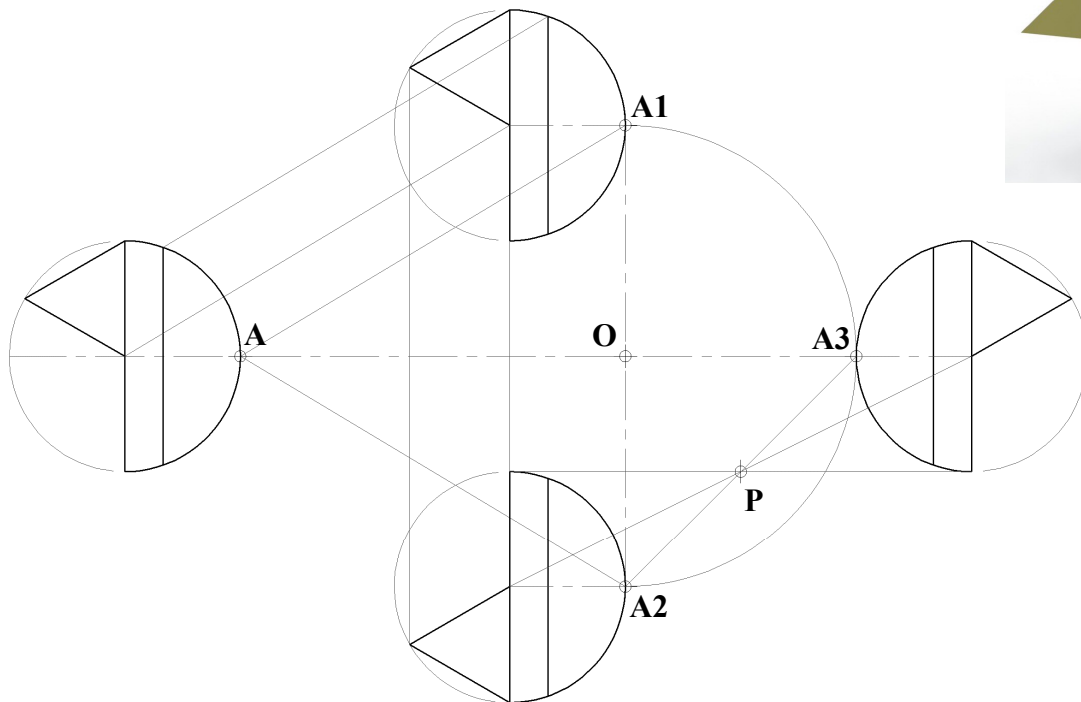
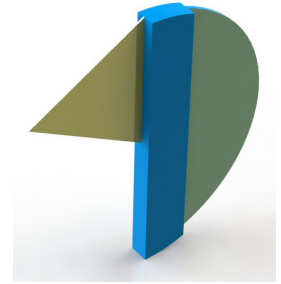

|                              |   |
|------------------------------|---|
| <b>Setting Up (16)</b>       |   |
| 10                           | Draw given figure: Circle ( <b>4 marks</b> ), 2 lines ( <b>2 x 1 marks</b> ), flag – 2 lines ( <b>2 x 2 marks</b> ) |
| 4                            | Locate points A, A1, A2, A3 ( <b>4 x 1 mark</b> )   |
| 2                            | Locate points <b>O</b> and <b>P</b>   |
| <b>Translation (14)</b>      |   |
| 4                            | Projection parallel to A-A1 ( <b>correct position and orientation</b> )   |
| 10                           | Drawing fig. as above   |
| <b>Axial Symmetry (14)</b>   |   |
| 4                            | Projection lines perpendicular to A-A3 ( <b>correct position and orientation</b> )                                  |
| 10                           | Drawing fig. as above   |
| <b>Central Symmetry (14)</b> |   |
| 4                            | Drawing lines through centre of point <b>P</b> ( <b>correct position and orientation</b> )                          |
| 10                           | Drawing fig. as above   |
| (12)                         | Drafting, accuracy and presentation   |
| <b>Total 70</b>              |   |

### Q 6 – Circles and Tangents

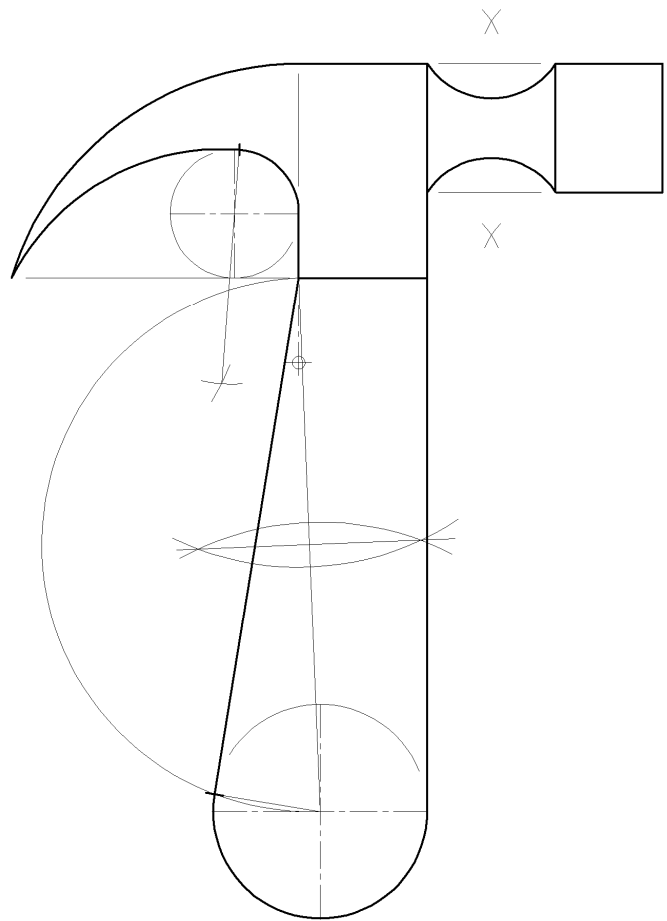
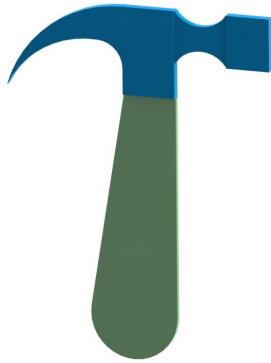

|                         |   |
|-------------------------|---|
| <b>Hammer Head (16)</b> |   |
| 4                       | 50 x 30 Rectangle (4 x 1 marks)   |
| 4                       | 30 x 25 Rectangle (4 x 1 marks)   |
| 8                       | R18 Arcs – Locate centres (2 x 2 marks), Draw Arcs (2 x 2 marks)                  |
| <b>Claw (24)</b>        |   |
| 8                       | R70 Arc – Centre location (4 marks), Arc (4 marks)                                |
| 6                       | R15 Arc – Centre location (3 marks), Arc (3 marks)                                |
| 10                      | R55 Arc – Centre Location and point of contact (4 marks + 2 marks), Arc (4 marks) |
| <b>Handle (18)</b>      |   |
| 2                       | Vertical line   |
| 8                       | R25 Circle – Centre location (4 marks), Circle (4 marks)                          |
| 8                       | Tangent construction (6 marks) Tangent line (2 marks)                             |
| (12)                    | Drafting, accuracy and presentation   |
| <b>Total 70</b>         |   |