



*Leaving Certificate Examination*

***Technology***  
***Higher Level***

***Friday, 19 June***  
***Afternoon, 2:00 - 4:30***

There are **three** Sections in this paper. Attempt **all three** Sections.

**Section A:** Core - Short-answer questions.

**Section B:** Core - Long-answer questions.

**Section C:** Options - Long-answer questions.

***Section A - Core*** (72 marks)

***Instructions:***

- (a) Answer **any twelve** questions in the spaces provided.  
All questions in Section A carry 6 marks.
- (b) Draw all sketches in pencil.
- (c) Hand up this booklet at the end of the examination.
- (d) Write your examination number in the box provided  
and on all other pages used.

<b>Centre Number</b>

<b>Section</b>	<b>Mark</b>
Section A	
Section B	
Section C	
Total	
Grade	

***Examination Number:***



4.

(i) Using the following information, calculate the gear ratio of the gear train shown.

Note: The position of gear **B** is fixed.

Teeth - **A**: 36 **B**: 18 **C**: 72.

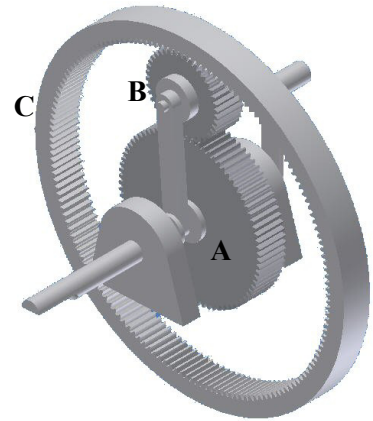

Calculation:

(ii) If the speed of gear **A** is 40 rev/min, calculate the speed of gear **C**.

Calculation:

5. Control Systems may be either *open loop* or *closed loop*.

What is meant by the terms open loop and closed loop?

(i) Open loop:

---

---

(ii) Closed loop:

---

---

6. (i) What is the difference between a DVD-R and a DVD-RW disc?

---

---

(ii) Which type of disc would be more suitable for the distribution of a software application?

Give **one** reason for your answer.

Type: \_\_\_\_\_

Reason: \_\_\_\_\_  
\_\_\_\_\_

7. Describe **two** specific safety precautions that should be observed when:



Using an adhesive to join acrylic parts:

- (i) \_\_\_\_\_
- (ii) \_\_\_\_\_

Using a drilling machine:

- (i) \_\_\_\_\_
- (ii) \_\_\_\_\_

8. What is meant by **each** of the following terms in describing the properties of materials?

(i) Elasticity: \_\_\_\_\_  
 \_\_\_\_\_  
 \_\_\_\_\_

(ii) Plasticity: \_\_\_\_\_  
 \_\_\_\_\_  
 \_\_\_\_\_

9. The graphics below show a resistor colour code table and two resistors **R1** and **R2**.

Brown	0	
Black	1	
Red	2	
Orange	3	
Yellow	4	
Green	5	
Blue	6	
Violet	7	
Grey	8	
White	9	
Gold	0.1	

(i) Calculate the values of resistors **R1** and **R2**.



**R1** - Brown, Black, Red, Gold. Value = \_\_\_\_\_



**R2** - Brown, Yellow, Red, Gold. Value = \_\_\_\_\_

(ii) **R1** and **R2** are used to complete the circuit shown.

Calculate the value of  $V_{OUT}$  in this circuit.

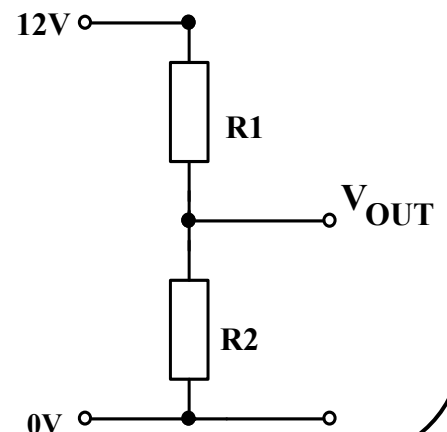

Calculation:

10. The graph shows the sales of a typical product over its life cycle. The graph is divided into five stages from Development to Decline as shown.

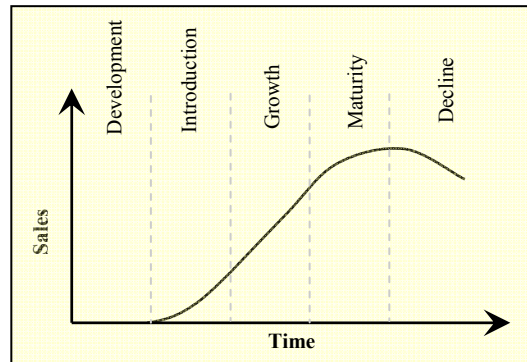

Describe **any three** of these stages of product life cycle.

1. \_\_\_\_\_  
\_\_\_\_\_
2. \_\_\_\_\_  
\_\_\_\_\_
3. \_\_\_\_\_  
\_\_\_\_\_

11. (i) Describe the operation of the relay shown making reference to the coil, contacts and iron core.

\_\_\_\_\_

\_\_\_\_\_

\_\_\_\_\_

\_\_\_\_\_

\_\_\_\_\_

\_\_\_\_\_

\_\_\_\_\_

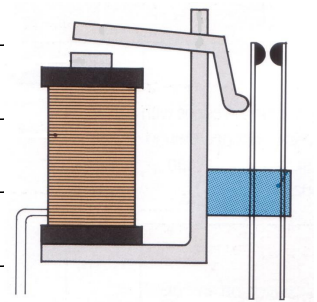

- (ii) Give an example of where a relay could be used.

\_\_\_\_\_

\_\_\_\_\_

**12.** The graphic shows the *machine heads* of a guitar. The machine heads allow the guitar to be tuned.

(i) Name the mechanism used in the machine heads.

\_\_\_\_\_

(ii) Explain why this mechanism is suitable for this purpose.

\_\_\_\_\_  
\_\_\_\_\_  
\_\_\_\_\_  
\_\_\_\_\_

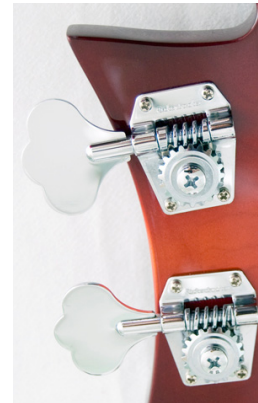

**13.** Make a well-proportioned freehand sketch of three principal orthographic views of the whistle shown.

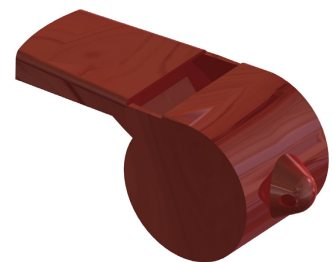

**14.** Tennis rackets are produced from a range of materials.

Outline **two** important considerations in selecting a suitable material for:



The frame **A**:

(i) \_\_\_\_\_

(ii) \_\_\_\_\_

The strings **B**:

(i) \_\_\_\_\_

(ii) \_\_\_\_\_

**15.** The graphic shows an extract from the manual supplied with a coffee machine.

(i) Name the type of pictorial representation used.

\_\_\_\_\_

(ii) Use **two** graphic techniques to enhance the graphic representation of the parts labelled **2** and **7**.

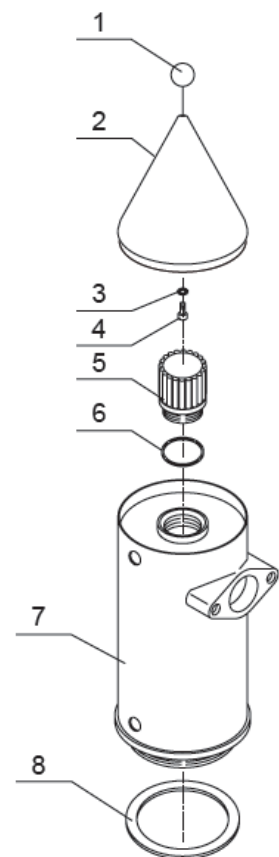

**Blank Page**