



Junior Certificate Examination, 2010

Materials Technology - Wood
Higher Level
Section B (60 marks)

Monday, 21 June
Afternoon 2:00 - 4:00

Instructions

- (a)*** Answer ***three*** questions. All questions carry equal marks.
- (b)*** You may answer either question 5A ***or*** question 5B but ***not both*** of them.
- (c)*** Where sketches are required they may be done freehand or on the graph paper provided.
- (d)*** Write your examination number on the answer book and on all other pages used.
- (e)*** ***Question 1*** from this section must be answered on drawing paper. All other questions should be answered on the answer book supplied.

1. The diagram shows a dimensioned isometric drawing of a model of a wooden chair for a child.

Frame Material: 40mm x 18mm

Seat, Back and Table thickness: 18mm

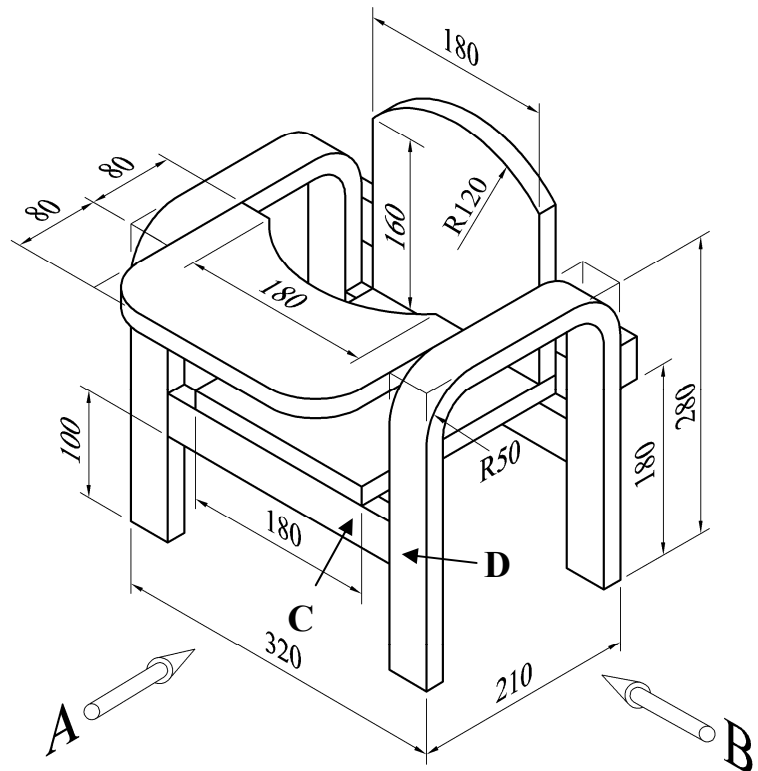

- (i) To a scale of 1:2, draw a **front elevation** of the chair looking in the direction of arrow **A** and an **end elevation** looking in the direction of arrow **B**.

Include **FOUR** main dimensions on your drawing.

- (ii) With the aid of notes and *neat freehand sketches*, describe a suitable method of jointing the members **C** and **D**.

2. (i) Two stages in a typical design process are **Sketches/Working Drawings** and **Evaluation**. Explain these **TWO** stages.

- (ii) The diagram shows a collection of items and equipment used by a student when studying or doing homework.

Using notes and *neat freehand sketches* to communicate your ideas, design a suitable desktop unit that would store these items and that would also hold a text book open at a suitable reading angle.



- (iii) State **TWO** specific design requirements that must be considered for the proposed unit.
- (iv) Describe using notes and *neat freehand sketches* how you incorporated these requirements into your final design solution.

3. The diagram on the right shows one method of seasoning timber to reduce its moisture content.

- (i) What is the correct name for this method of seasoning?
- (ii) Explain what happens during the seasoning process, making particular reference to the function of the parts labelled in the diagram.
- (iii) Name **ONE** other method of seasoning timber.

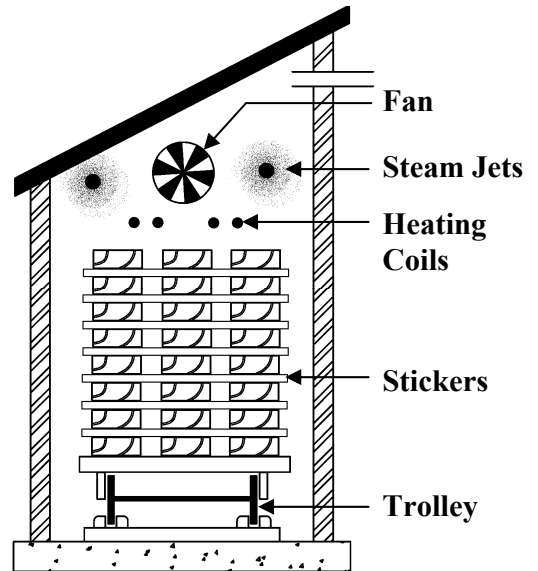

State **TWO** advantages and **TWO** disadvantages of this second method of seasoning.

- (iv) The diagram on the right shows a board which warped badly during seasoning. Explain why this might have happened and, using notes and a *neat freehand sketch*, show how the warping might have been prevented.

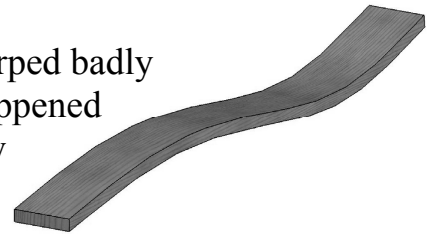

4. (i) State the correct name for the wood boring tools labelled A, B and C.

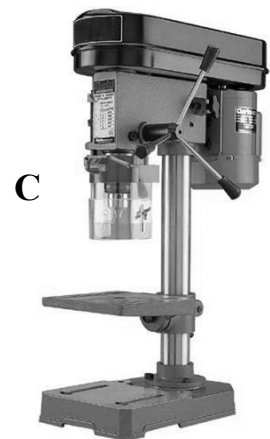
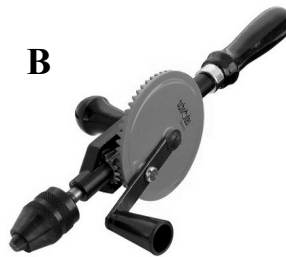
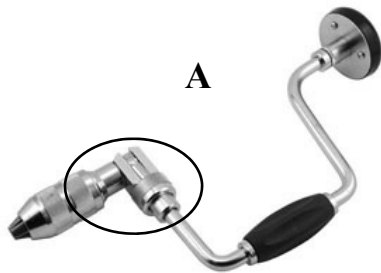

- (ii) The diagram below shows a part of tool A enlarged. Name the part and describe how it functions.



- (iii) The bit shown on the right is used with tool A to bore holes. Using notes and *neat freehand sketches*, describe the stages involved in boring such a hole **through** a piece of wood using this tool.



5. Answer 5A or 5B

5A. The diagram shows a cook book stand which is made from acrylic.

- (i) Using a *neat freehand sketch*, draw the development that would be marked out on the acrylic sheet in order to manufacture this stand.
- (ii) With the aid of *neat freehand sketches* describe, in detail, the steps you would follow to **CUT OUT** and **FORM** the holder.
- (iii) It is proposed that the stand would be fixed to a hardwood base. With the aid of *neat freehand sketches* suggest a suitable design for the wooden base.
- (iv) The stand is to be fixed to the hardwood base using screws. With the aid of notes and *neat freehand sketches*, describe how you would drill the appropriate holes in both the acrylic and the hardwood base for the insertion of the screws.



OR

5B. The diagrams show three carving methods.

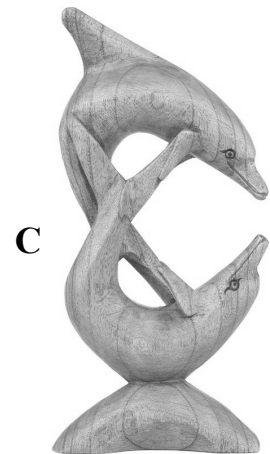
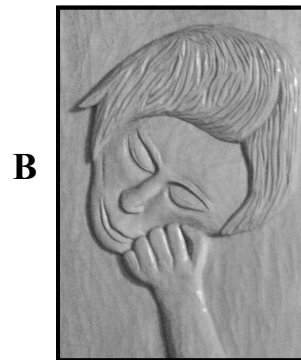

- (i) Name the **THREE** methods of carving shown in the diagrams.
- (ii) With the aid of notes and *neat freehand sketches* describe how you would transfer the design from a sheet of paper onto the wooden panel in piece **B** prior to carving.
- (iii) Select an appropriate clear finish for piece **C** and give **TWO** reasons in support of your choice.
- (iv) Describe, in detail, how you would apply your chosen finish.