



Coimisiún na Scrúduithe Stáit
State Examinations Commission

LEAVING CERTIFICATE EXAMINATION, 2021

ENGINEERING – PRACTICAL EXAMINATION HIGHER AND ORDINARY LEVELS

Adjusted Assessment Arrangements for 2021 - Please Read Carefully

Instructions to teachers

1. Please familiarise yourself with the adjusted assessment arrangements for candidates taking the state examinations in the 2020/21 school year that were issued by the Department of Education and Skills. Preparation of materials and components for the 2021 Leaving Certificate Engineering Practical Examination must be carried out in accordance with these adjusted arrangements.
2. The adjusted arrangements for the 2021 Leaving Certificate Engineering Practical Examination, state that candidates do not have to partake in the preparation of the materials and components required for this examination. Therefore, candidates will not be awarded marks for the manufacture of this preparatory work.
3. The Engineering teacher may prepare the materials and make the components required for the examination, according to the materials list and drawings provided on pages 2 and 3. Alternatively, the school may outsource this work. This preparatory work must be completed by late April 2021, in advance of the three-day Engineering Practical Examination schedule.
4. The equipment, materials and components required for the 2021 Leaving Certificate Engineering Practical Examination are provided on pages 2 and 3.
5. All prepared materials and finished components should be stored safely until examination day.
6. It is important that all drilling machines are fully operational and complete with accurate chucks, machine vices and clamps. Drills as specified are required to be in optimum machining condition.

EQUIPMENT LIST

Lathes and Drilling machines with protective goggles.
 Usual marking-out and measuring tools.
 Usual bench fitting tools and equipment.
 Height gauge/scribing block and surface plate (one per five candidates).
 M5 and M8 taps with suitable tapping wrench to suit machine screws.
 Set of drills; Ø4.2, Ø5.5, Ø6.8 and Ø8 with spares.

Set of usual files, to include:

- 250 mm hand rough
- 250 mm hand smooth
- 200 mm square rough
- 200 mm square smooth
- 150 mm square smooth
- 150 mm half-round smooth
- 200 mm half-round rough
- 150 mm hand smooth
- 1 set of needle files per five candidates.

Junior and standard hacksaws and blades.
 Hand-held electrical engraving tool or number punches.
 One pair of aluminium or fibre protective vice clamps per candidate.
Allen Keys to suit machine screws supplied.
 Half sheet of fine grade emery cloth per candidate.
 Half sheet of medium grade emery cloth per candidate.

Materials list - per candidate

Required	Material	Size
1 piece	Aluminium bar	To make part A
1 piece	Brass bar	To make part B
1 piece	Aluminium bar	To make part C
1 Threaded bar	Brass or Steel	To make part D
1 piece	Brass bar	To make part E
1 piece	Brass bar	To make part F
2 pieces	Aluminium	To make parts G
1 piece	Aluminium bar	To make part H
2 Machine screws, Allen Button Head	Brass or Steel	To make parts I
1 piece	Clear Polycarbonate	36 × 6 × 80
1 piece	Aluminium	40 × 4 × 140
2 pieces	Brass	20 × 3 × 70
2 pieces	Aluminium	50 × 4 × 72
4 Machine screws, Allen Button Head	Brass or Steel	M5 × 8

Note: Bold dimensions are finished sizes.

Note: It is required to prepare materials and make Parts A to I, according to the materials list on page 2 and the drawings shown below by late April 2021, in advance of the three-day Engineering Practical Examination schedule.

A

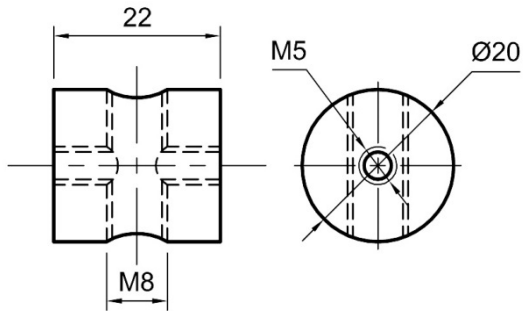

B

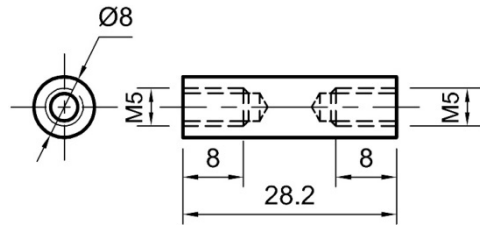

C

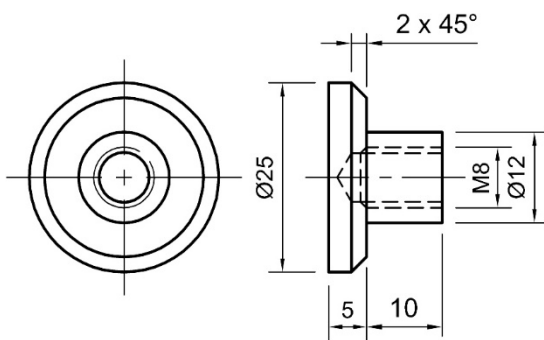

D

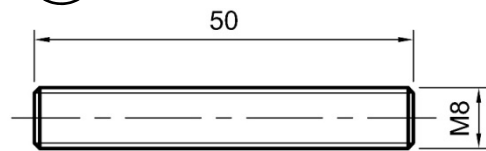

E

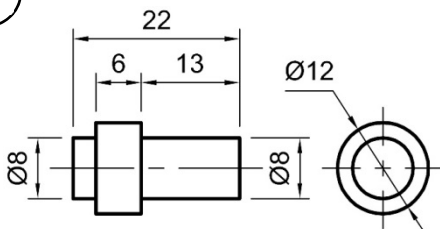

F

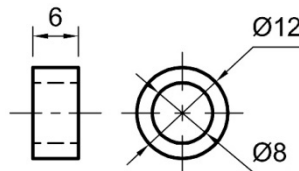

G 2 OFF

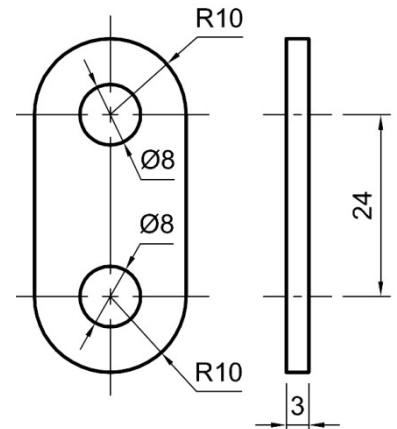

H

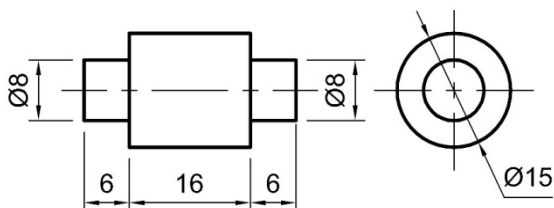

I 2 OFF

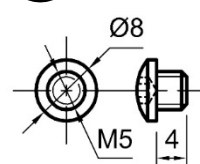

Note: Part B, Part E, Part H and Part I should rotate freely in a Ø8 mm drilled hole.

Note: General Tolerance ± 0.2 mm.

Blank Page