

MARKING SCHEME
JUNIOR CERTIFICATE EXAMINATION 2005
MATHEMATICS – ORDINARY LEVEL – PAPER 2

GENERAL GUIDELINES FOR EXAMINERS

1. Penalties of three types are applied to candidates' work as follows:
 - Blunders - mathematical errors/omissions (-3)
 - Slips- numerical errors (-1)
 - Misreadings(provided task is not oversimplified) (-1).

Frequently occurring errors to which these penalties must be applied are listed in the scheme. They are labelled: B1, B2, B3,..., S1, S2,..., M1, M2,...etc. These lists are not exhaustive.

2. When awarding attempt marks, e.g. Att(3), note that
 - any *correct, relevant* step in a part of a question merits at least the attempt mark for that part
 - if deductions result in a mark which is lower than the attempt mark, then the attempt mark must be awarded
 - a mark between zero and the attempt mark is never awarded.
3. Worthless work is awarded zero marks. Some examples of such work are listed in the scheme and they are labelled as W1, W2,...etc.
4. The phrase “hit or miss” means that partial marks are not awarded – the candidate receives all of the relevant marks or none.
5. The phrase “and stops” means that no more work is shown by the candidate.
6. Special notes relating to the marking of a particular part of a question are indicated by an asterisk. These notes immediately follow the box containing the relevant solution.
7. The sample solutions for each question are not intended to be exhaustive lists – there may be other correct solutions.
8. Unless otherwise indicated in the scheme, accept the best of two or more attempts – even when attempts have been cancelled.
9. The *same* error in the *same* section of a question is penalised *once* only.
10. Particular cases, verifications and answers derived from diagrams (unless requested) qualify for attempt marks at most.
11. A serious blunder, omission or misreading results in the attempt mark at most.
12. Do not penalise the use of a comma for a decimal point, e.g. €5.50 may be written as €5,50.

QUESTION 1

Part (a)	10 marks	Att 3
Part (b)	20 marks	Att 7
Part (c)	20 marks	Att 7

Part (a)	10 marks	Att 3
-----------------	-----------------	--------------

Subtract 500 g from 5640 g, and give your answer in kg

✍ (a) $5640 \text{ g} - 500 \text{ g} = 5140 \text{ g}$ or $500 \text{ g} = 0.5 \text{ kg}$ or $5640 \text{ g} = 5.640 \text{ kg}$

$$5140 \text{ g} = \frac{5140}{1000} = 5.140 \text{ kg}$$

7
9 10

3
7 10

* Correct answer without work merits 7 marks ✍

Blunders (-3)

- B1 Incorrect conversion or no conversion
- B2 Incorrect mathematical operation with work and continues
- B3 Place value or decimal error when subtracting eg gives 640 g in method 1 or has more than one decimal point in a figure
- B4 Fails to subtract – method 2
- B5 Incorrect order of subtraction

Slips (-1)

- S1 Numerical slips to a maximum of -3 but note B3
- S2 Leaves as $\frac{5140}{1000}$ kg method 1

Attempts (3 marks)

- A1 Converts one number correctly and stops eg 0.5 kg
- A2 States 1000g = 1 kg and stops
- A3 Some correct effort at conversion
- A4 5140 without work and stops

Worthless (0)

- W1 Incorrect answer without work

(ii) Cormac left Limerick at 11:15. At what time did he arrive in Cork?



(ii) $11:15 + 1:15 = 12:30$ or 'Half past 12'

- * Correct answer without work merits 2 marks
- * Accept candidate's answer from part (i)

Blunders (-3)

- B1 Subtracts instead of adding with work
- B2 Correctly adds arbitrary time to 11:15 with work
- B3 Incorrect or no conversion of minutes to hours, if applicable

Slips (-1)

- S1 Numerical slips to a maximum of -3

Attempts (2 marks)

- A1 States 1 hour = 60 minutes and stops

Worthless (0)

- W1 Incorrect answer without work

- (iii) Cormac's car used 1 litre of petrol for every 16 km travelled. On that day petrol cost 99 cent per litre. Find the cost of the petrol used on Cormac's journey from Limerick to Cork. Give your answer to the nearest euro.



(iii) Litres used = $\frac{100}{16} = 6.25$

Cost = $6.25 \times 99\text{c} = 618.75\text{c} = \text{€}6.1875 = \text{€}6$ or Cost = $6.25 \times \text{€}0.99 = \text{€}6.1875 = \text{€}6$

- * Correct answer without work merits 2 marks
- * Accept conversion of cent to euro without work if correct

Blunders (-3)

- B1 Incorrect calculation of litres
- B2 Incorrect calculation of cost
- B3 Incorrect conversion of cents to euro or no conversion
- B4 Uses arbitrary number of litres and continues

Slips (-1)

- S1 Numerical slips to a maximum of -3
- S2 Fails to round off, or rounds off incorrectly or early rounding off.

Attempts (2 marks)

- A1 Calculates number of litres used with work and stops
- A2 Any relevant work eg $16+16+16$
- A3 States 1 euro = 100c and stops

Worthless (0)

- W1 Incorrect answer without work

Part (c)

20 marks (10,5,5)

Att 7 (3,2,2)

A field has shape and measurements as shown in the diagram.

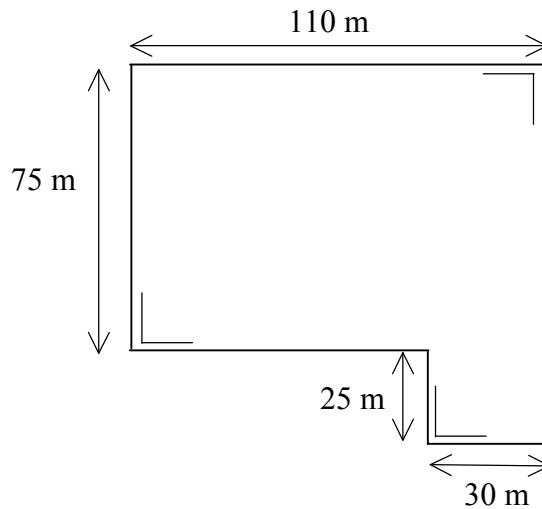

Part (c) (i)

10 marks

Att 3

(i) Find, in metres, the length of the perimeter of the field.



$$(i) \quad 110 \text{ m} + 75 \text{ m} + 80 \text{ m} + 25 \text{ m} + 30 \text{ m} + 100 \text{ m} = 420 \text{ m}$$

Method 1



$$P = 2(L) + 2(W) = 2(100) + 2(110) = 200 + 220 = 420 \text{ m}$$

Method 2

* Correct answer without work merits 7 marks

Blunders (-3)

B1 Missing or extra segment apply once only (Method 1)

B2 Incorrect relevant formula eg $L + W$ (Method 2)

B3 Incorrect substitution/dimension apply once only (Method 2)

Slips (-1)

S1 Numerical slips to a maximum of -3

Attempts (3 marks)

A1 Finds any missing dimension(s) on diagram and stops (accept for this part only)

A2 Finds area of part or whole with work

A3 Any relevant work eg understands the meaning of perimeter

A4 Correct formula for perimeter and stops

Worthless (0)

W1 Incorrect answer without work

(ii)

Find, in m^2 , the area of the field.

 (ii)	$A = L \times W$	2
Area = $110 \times 100 \text{ m}^2 - 25 \times 80 \text{ m}^2$	$A = 110 \times 75 \text{ m}^2 + 25 \times 30 \text{ m}^2$	$A = 75 \times 80 \text{ m}^2 + 30 \times 100 \text{ m}^2$
$= 11000 \text{ m}^2 - 2000 \text{ m}^2$	$= 8250 \text{ m}^2 + 750 \text{ m}^2$	$= 6000 \text{ m}^2 + 3000 \text{ m}^2$
$= 9000 \text{ m}^2$	$= 9000 \text{ m}^2$	$= 9000 \text{ m}^2$
5	5	5

* Correct answer without work merits 2 marks *Blunders (-3)*

- B1 Incorrect relevant formula eg $L \times L$ and continues
- B2 Missing or extra rectangle in any of the above methods
- B3 Incorrect decimal point
- B4 Incorrect substitution/dimension

Slips (-1)

- S1 Numerical slips to a maximum of -3
- S2 Fails to add or subtract areas of rectangles

Attempts (2 marks)

- A1 Some correct step with work and stops
- A2 Product of any two dimensions with work shown
- A3 Area = $L \times W$ and stops
- A4 Finds perimeter correctly or incorrectly with work shown

Worthless (0)

- W1 Incorrect answer without work

- (iii) Mary bought the field at a cost of €20,000 per hectare.
How much did Mary pay for the field?

	(iii)	$9000\text{m}^2 = \frac{9000}{10000} = 0.9 \text{ hectares}$	2
		$\text{Cost} = 0.9 \times \text{€}20\,000 = \text{€}18\,000$	5

- * Correct answer without work merits 2 marks 
- * Accept candidate's answer from part (ii)
- * Note: Special S2

Blunders (-3)

- B1 Error in converting m^2 to hectares or no conversion, but see S2
B2 Incorrect mathematical operation

Slips (-1)

- S1 Numerical slips to a maximum of -3
S2 Only converts to ares with work ie divides by 100

Attempts (2 marks)

- A1 $9000 \times \text{€}20\,000$
A2 States $100 \text{ m}^2 = 1 \text{ are}$ or $1 \text{ hectare} = 100 \text{ ares}$

Worthless (0)

- W1 Incorrect answer without work

QUESTION 2

Part (a)	10 marks	Att 3
Part (b)	20 marks	Att 7
Part (c)	20 marks	Att 8

A rectangular box has measurements as shown.

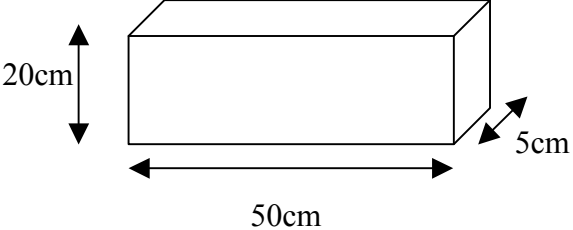

20cm

50cm

5cm

Part (a)	10 marks	Att 3
-----------------	-----------------	--------------

Calculate the volume of the box in cm^3

	(a)	$\begin{aligned} \text{Volume} &= L \times W \times H \\ &= 20 \times 50 \times 5 \\ &= 5000 \text{ cm}^3 \end{aligned}$	<p>3</p> <p>7</p> <p>10</p>
---	-----	--	-----------------------------

* Correct answer without work merits 7 marks 

Blunders (-3)

- B1 Incorrect formula eg correct Surface Area
- B2 Incorrect substitution or omission or extra, each time
- B3 Incorrect decimal point

Slips (-1)

- S1 Numerical slips to a maximum of -3

Attempts (3 marks)

- A1 Some correct step with work and stops
- A2 Correct formula only and stops
- A3 Writes 20×50 or 20×5 or 5×50 and stops

Worthless (0)

- W1 Incorrect answer without work
- W2 Adds $20 + 5 + 50$ only

Part b

20 marks (5, 5, 10)

Att 7(2, 2, 3)

The front wheel of a bicycle has a diameter of 56 cm.

(b) (i)

5 marks

Att 2

(i) Calculate, in cm, the length of the radius of the wheel.



$$(i) \text{ Radius} = \frac{\text{Diameter}}{2} = \frac{56}{2} = 28 \text{ cm}$$

* Correct answer without work merits 2 marks

* Do not penalise same error twice in part (b)

Blunders (-3)

B1 Divides by incorrect number with work

B2 Decimal error

Slips (-1)

S1 Numerical slips to a maximum of – 3

S2 Leaves as $\frac{56}{2}$

Attempts (2 marks)

A1 States ‘Diameter = 2 × radius’ and stops

Worthless (0)

W1 Incorrect answer without work

Part (b) (ii)

5 marks

Att 2

(ii) Calculate, in cm, the length of the circumference of the wheel.
Take π as $\frac{22}{7}$.

	(ii) Length = $2\pi r$ $= 2 \times \frac{22}{7} \times 28$ $= 176 \text{ cm}$	2 2 5	or	Length = πd $= \frac{22}{7} \times 56$ $= 176 \text{ cm}$	2 2 5
---	---	-------------	----	--	-------------

- * Correct answer without work merits 2 marks 
- * Accept candidate's answer from part (i)

Blunders (-3)

- B1 Incorrect relevant formula eg area disc or incorrect multiple of πr or πd
- B2 Incorrect r unless penalised in (i)
- B3 Correct substitution and stops
- B4 $\pi \neq \frac{22}{7}$ or answer in terms of π

Slips (-1)

- S1 Numerical slips to a maximum of -3

Attempts (2 marks)

- A1 Multiplies r correctly by any number except 1 or 2π with work shown

Worthless (0)

- W1 Incorrect answer without work

(iii) How far does the bicycle travel when the wheel makes 250 complete turns?
Give your answer in metres.

	(iii) Distance = 250 × 176	3	or	176 cm = 1.76 m	3
	= 44 000 cm	7		Distance = 250 × 1.76	7
	= 440 m	10		= 440 m	10

- * Correct answer without work merits 7 marks 
- * Accept candidate's answer from part (ii)

Blunder (-3)

- B1 Incorrect conversion or no conversion
- B2 Division instead of multiplication
- B3 Multiplies their circumference by incorrect figure unless clearly a misreading
- B4 Decimal error
- B5 Multiplies an arbitrary number by 250 with work shown and continues

Slips (-1)

- S1 Numerical slip to a maximum of -3
- S2 Leaves as $\frac{44000}{100}$

Attempts (3 marks)

- A1 Convert 176 cm to metres and stops – first step of scheme
- A2 Any relevant work eg 44 000 without work or brings down answer from (ii)

Worthless (0)

- W1 Incorrect answer without work

Part (c)

20 marks (5,5,5,5)

Att 8 (2,2,2,2)

A solid cylinder has radius 4 cm and height 14 cm.

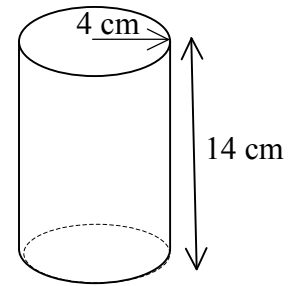

Part (c) (i)

5 marks

Att 2

(i) Find the volume of the cylinder in terms of π .

 (i)	Volume = $\pi r^2 h = \pi \times 4^2 \times 14$	2
	= $\pi \times 16 \times 14$	2
	= $\pi \times 224 \text{cm}^3$	5

* Correct answer without work merits 2 marks 

Blunders (-3)

- B1 Incorrect relevant formula eg surface area $2\pi rh$ or incorrect multiple of, $\pi r^2 h$ or πr^2 , with work.
- B2 Incorrect substitution
- B3 Mathematical error eg $4^2 = 8$
- B4 Not in terms of π , substitutes in a value

Slips (-1)

S1 Numerical slips to a maximum of -3

Attempts (2 marks)

A1 Any relevant work

Worthless (0)

W1 Incorrect answer without work

(ii)	Find the curved surface area of the cylinder in terms of π .
------	--



(ii) Surface area = $2\pi rh$	2
$= 2 \times \pi \times 4 \times 14$	2
$= 112 \times \pi$ or $112\pi \text{ cm}^2$	5

* Correct answer without work merits 2 marks

Blunders (-3)

- B1 Incorrect relevant formula eg multiple of $\pi r^2 h$ or πr^2 or incorrect multiple of $2\pi r$, with work
- B2 Incorrect substitution
- B3 Mathematical error eg adds instead of multiplying in formula
- B4 Not in terms of π , substitutes in a value – if not penalised already

Slips (-1)

- S1 Numerical slips to a maximum of -3

Attempts (2 marks)

- A1 Any relevant work eg 112 without work

Worthless (0)

- W1 Incorrect answer without work

(iii) Find the total surface area of the cylinder in terms of π .



(iii) Total surface area = Curved surface area + 2 × Area Disc (Area Top + Bottom) 2

$$= [112\pi] + 2\pi r^2 \quad 2$$

$$= [112\pi] + 2 \times \pi \times 4^2 \quad 2$$

$$= 112\pi + 32\pi \quad 4$$

$$= 144\pi \quad 5$$

- * Correct answer without work merits 2 marks 
- * Accept candidate's answer from part (ii)

Blunders (-3)

- B1 Incorrect relevant formula must relate to cylinder or circle, with work
- B2 Incorrect substitution
- B3 Mathematical error
- B4 Not in terms of π , substitutes in a value, if not penalised already

Slips (-1)

- S1 Numerical slips to a maximum of -3
- S2 Only includes area of one disc

Attempts (2 marks)

- A1 Finds area of one disc only with work
- A2 Some correct step and stops eg states total surface area = curved + plus top and/or bottom
- A3 Answer part (ii) carried forward
- A4 Mentions Top and/or bottom

Worthless (0)

- W1 Incorrect answer without work

- (iv) A sphere has the same surface area as the total surface area of the above cylinder.
Find, in cm, the radius of this sphere

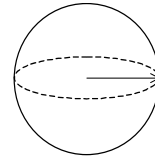

(iv) Surface area sphere = $4\pi r^2$	2
$4\pi r^2 = 144\pi$	2
$4r^2 = 144$	2
$r^2 = \frac{144}{4}$	2
$r^2 = 36$	2
$r = 6$ or $\sqrt{36}$	5

- * Correct answer without work merits 2 marks
- * Accept candidate's answers from parts (ii) and (iii)

Blunders (-3)

- B1 Incorrect relevant formula eg multiples of $\frac{4}{3}\pi r^3$, $\pi r^2 h$, $2\pi r h$, $2\pi r$ or πr^2 - with work
- B2 Incorrect substitution
- B3 Mathematical error eg transposing error

Slips (-1)

- S1 Numerical slips to a maximum of -3

Attempts (2 marks)

- A1 First line of scheme
- A2 Some correct step eg answer from (iii) carried forward
- A3 Effort at trial and error

Worthless (0)

- W1 Incorrect answer without work

QUESTION 3

Part (a)	10 marks	Att 3
Part (b)	20 marks	Att 7
Part (c)	20 marks	Att 7

Part (a) 10 marks Att 3

(a) Find the mean of the numbers: 4, 6, 7, 12, 16.



(a) Mean = $\frac{\Sigma x}{n}$ 3
= $\frac{4+6+7+12+16}{5}$ 7
= $\frac{45}{5} = 9$ 10
(9 marks)

* Correct answer without work merits 7 marks

Blunders (-3)

- B1 Multiplies instead of adds
- B2 Incorrect divisor except 1
- B3 Omits a variable each time
- B4 Inverted fraction

Slips (-1)

- S1 Numerical slips to a maximum of -3
- S2 $\frac{45}{5}$ and stops

Attempts (3 marks)

- A1 Addition of data only
- A2 Partial addition with work and stops
- A3 Idea of mean indicated e.g. $\frac{\Sigma x}{n}$ or verbal description
- A4 "Median is 7" and stops
- A5 45 or 5 without work

Worthless (0)

- W1 Incorrect answer without work

Part (b)

20 marks (5,10,5)

Att 7(2,3,2)

The trend graph below shows the rainfall in mm for the first six months of last year.

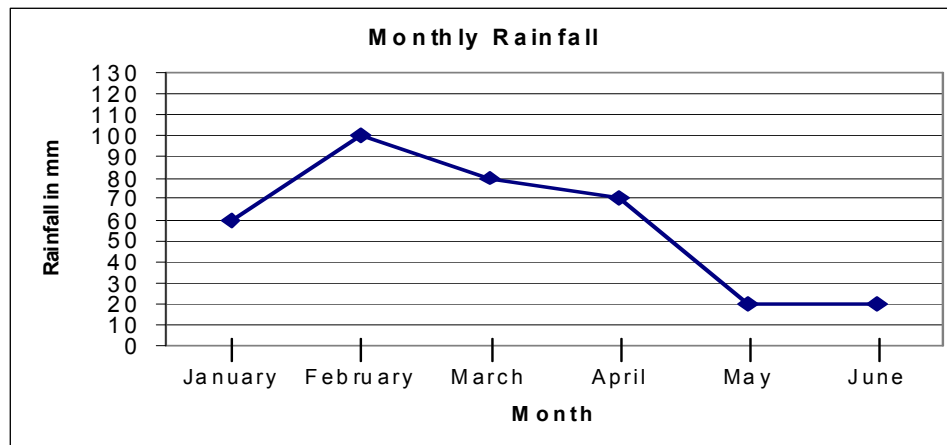

Use the trend graph to answer the following questions.

Part (b) (i)

5 marks

Att 2

(i) Which of the given months had the highest rainfall?

(i) February

Blunders (-3)

B1 Fails to identify month ie states highest is 100mm and stops

Attempts (2 marks)

A1 Lists the values but does not identify February

A2 Any list of months which includes February

Part (b) (ii)

10 marks

Att 3

(ii) What was the total rainfall, in mm, for the given six months?

 (ii) 60, 100, 80, 70, 20, 20	3
Total = 60+100+80+70+20+20	7
= 350 mm	10

* Correct answer without work merits 7 marks 

Blunders (-3)

- B1 Omits more than one entry
- B2 Fails to find total
- B3 Multiplies the numbers instead of adding

Slips (-1)

- S1 Numerical slips to a maximum of -3
- S2 Omits or fails to list one entry in addition

Misreadings (-1)

- M1 Incorrect entry, once only if consistent

Attempts (3 marks)

- A1 Lists the values
- A2 Any relevant step

Worthless (0)

- W1 Incorrect answer without work

(iii) What percentage of the total rainfall for the given six months fell in the month of April?

	(iii)	April = 70 Total = 350			
		Method 1		Method 2	
		$\% \text{ April} = \frac{70}{350} \times 100$	or	April: $\frac{70}{350} = \frac{1}{5}$	2
		= 20%		$\frac{1}{5} = 20\%$	5

- * Correct answer without work merits 2 marks 
- * Accept candidate's answer from part (ii)

Blunders (-3)

- B1 Multiplies by $\frac{350}{100}$ or similar
- B2 Mathematical or decimal error
- B3 Incorrect fraction in Method 2 $\frac{1}{5} \neq 20\%$
- B4 Omits 100 in Method 1, stops at 0.2

Slips (-1)

- S1 Numerical slips to a maximum of -3

Attempts (2 marks)

- A1 Some correct step and stops eg identifies April =70

Worthless (0)

- W1 Incorrect answer without work

Part (c)

20 marks (10, 5, 5)

Att 7 (3,2,2)

A survey was taken of 40 students, who owned mobile phones, to find out the Number of text messages they sent on a particular day. The table shows the results of the survey.

Number of text messages	0	1	2	3	4	5
Number of students	3	5	7	5	14	6

Part (c) (i)

10 marks

Att 3

(i)

Draw a bar chart of the data.

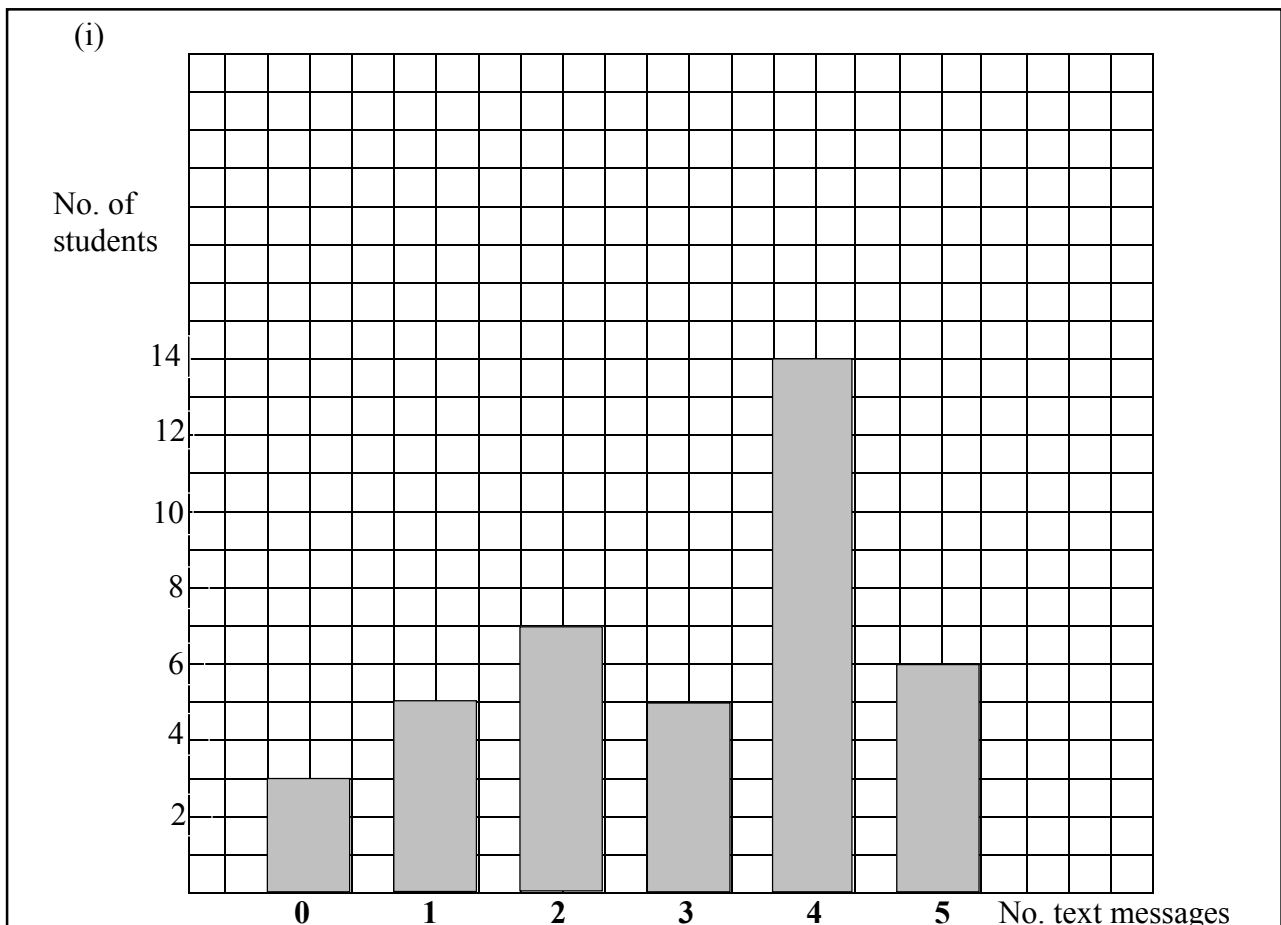

- * Accept horizontal or vertical bar chart
- * Accept 'lines' as bars
- * Accept bars of unequal widths
- * Labelling not require

Blunders (-3)

- B1 Axis with student numbers not graduated uniformly
- B2 Reverses variable and frequency when drawing
- B3 Draws a trend graph or pie chart

Slips (-1)

- S1 Each incorrect bar or bar omitted

Attempts (3 marks)

- A1 Graduates axis or axes only.

(ii)	What was the modal number of text messages sent on that day?
------	--

(ii)	4
------	---

Blunders (-3)

B1 Gives 5 as answer

B2 Calculates mean correctly

Slips (-1)

S1 Gives 14 as answer

Attempts (2 marks)

A1 Any correct step

Worthless (0)

W1 Incorrect answer unless specified

(iii)	Calculate the mean number of text messages sent on that day
-------	---

	(iii)	$\text{Mean} = \frac{\sum fx}{\sum f}$ $= \frac{(3 \times 0) + (5 \times 1) + (7 \times 2) + (5 \times 3) + (14 \times 4) + (6 \times 5)}{3 + 5 + 7 + 5 + 14 + 6}$	2
	or	$= \frac{0 + 5 + 14 + 15 + 56 + 30}{40}$ $= \frac{120}{40} = 3$	2
			5

* Correct answer without work merits 2 marks 

Blunders (-3)

B1 Multiplies instead of adds in denominator

B2 Adds instead of multiplies in numerator

B3 Incorrect denominator or no denominator e.g. $\frac{120}{6}$

B4 Inverted fraction

B5 Frequencies omitted in numerator e.g. $\frac{0+1+2+3+4+5}{40} = \frac{15}{40}$

B6 Omits two or more values in numerator

Slips (-1)

S1 Numerical slips to a maximum of -3

S2 $3(0) = 3$

S3 Omits one value in numerator- with work

S4 $\frac{120}{40}$ and stops

Attempts (2 marks)

A1 Mean = $\frac{\sum fx}{\sum f}$ and stops

A2 A relevant multiplication shown and stops

A3 Some correct work e.g. $\sum f$

A4 Average of frequencies e.g. $\frac{3+5+7+5+14+6}{6} = \frac{40}{6} = 6.667$

A5 $\frac{0+1+2+3+4+5}{6} = 2.5$

A6 40 or 120 without work

Worthless (0)

W1 Incorrect answer without work

QUESTION 4

Part (a)	10 marks	Att 3
Part (b)	20 marks	Att 8
Part (c)	20 marks	Att 8

Part (a) **10 marks** **Att 3**

(a) Construct a triangle pqr with $|pq| = 8\text{ cm}$, $|qr| = 10\text{ cm}$ and $|\angle pqr| = 30^\circ$
Label your diagram clearly.



(a) Diagram

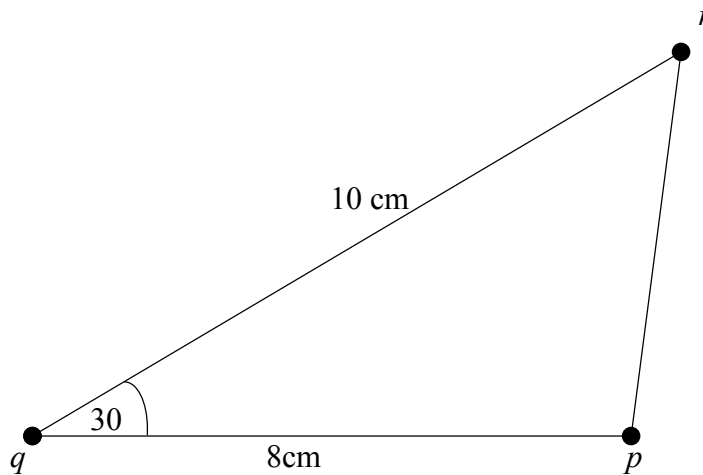

Side $[qp]$ or $[qr]$ 4 marks Angle $\angle pqr = 30^\circ$ 7 marks Finish 10 marks

- * Accept any units or any triangle in which $|pq|:|qr| = 8:10 = 4:5$
- * Accept base other than $[pq]$
- * Examiners must measure candidate's work
- * Tolerance, lines $\pm 5\text{ mm}$, or as appropriate, angle $\pm 5^\circ$:

Blunders (-3)

- B1 Each incorrect length ie outside tolerance
- B2 Incorrect angle ie outside tolerance

Slips (-1)

- S1 No labels or incorrect labels on diagram
- S2 r marked but fails to join p to r

Attempts (3 marks)

- A1 Pilot triangle diagram drawn

Notes: One side correctly drawn and labelled merits 4 marks
 Angle of 30° constructed with q marked merits 4 marks – no sides measured

Part (b)

20 marks (5, 5, 5, 5)

Att 8 (2, 2, 2, 2)

abc is an isosceles triangle with $|ca| = |cb|$

The side $[ab]$ is extended to d and $ce \perp ab$.

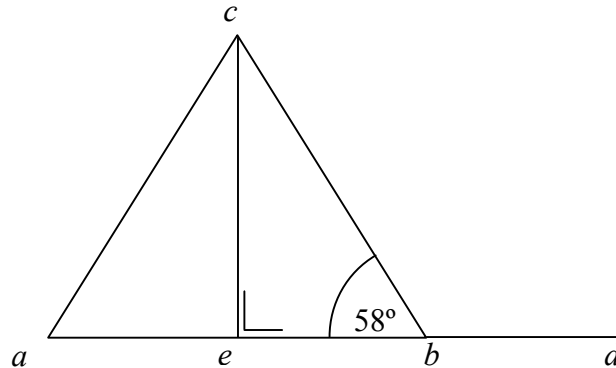

Part (b) (i)

5 marks

Att 2

- (i) Name an angle equal in measure to $\angle abc$.
Give a reason for your answer.

- | | | |
|-----|--|---|
| (i) | Name of angle: $\angle cab$ or $\angle bac$ or $\angle eac$ or $\angle dac$ | 4 |
| | Reason: Angles opposite equal sides are equal in measure.
Angles at the base of an isosceles triangle are equal
Base angles of an isosceles triangle are equal | 5 |

Blunder (-3)

B1 States $\angle acb$ - incorrect angle in the isosceles triangle

Slips (-1)

S1 Correct answer without reason or incorrect reason

S2 Marks 58° or shades $\angle cab$ on diagram but fails to name – may be subject to S1 also

S3 Names as $\angle a$

Attempts (2marks)

A1 Correctly finds any other angle in the triangle(s)

A2 States the three angles in a triangle sum to 180°

Part (b) (ii)

5 marks

Att 2

(ii) Given that $|\angle abc| = 58^\circ$, find $|\angle cbd|$ and give a reason for your answer.

$$(ii) \quad |\angle cbd| = [180^\circ - 58^\circ] = 122^\circ$$

Reason: A straight angle measures 180°

Equals $\angle cab + \angle acb$ - accept even if $\angle acb$ not found

Accept $180^\circ - 58^\circ$ rewritten

Blunders (-3)

B1 Straight angle $\neq 180^\circ$

Slips (-1)

S1 Correct answer without reason or incorrect reason

S2 Numerical slips to a maximum of -3

Attempts (2 marks)

A1 Mentions a straight angle equals 180° and stops or mentions 180°

A2 Mentions a relevant theorem

Part (b) (iii)

5 marks

Att 2

(iii) Given that $|ab| = 10$ cm and $|ce| = 8$ cm, find the area of Δabc .



(iii)

$$\begin{aligned} \text{Area} &= \frac{1}{2} \times \text{base} \times \text{height} & 2 \\ &= \frac{1}{2} \times 10 \times 8 & 2 \\ &= 40\text{cm}^2 & 5 \end{aligned}$$

* Correct answer without work merits 2 marks 

Blunders (-3)

- B1 Incorrect relevant formula eg missing the $\frac{1}{2}$
- B2 Incorrect substitution
- B3 Mathematical error

Slips (-1)

- S1 Numerical slips to a maximum of -3

Attempts (2 marks)

- A1 States formula for the area of a triangle and stops
- A2 Any relevant work eg $\frac{10}{2} = 5$

Worthless (0)

- W1 Incorrect answer without work

(iv) ce is the bisector of $\angle acb$.
Show that Δace and Δbce are congruent.

<p>(iv) $\Delta ace \equiv \Delta bce$ or $\Delta ace \equiv \Delta bce$ or $\Delta ace \equiv \Delta bce$</p> <p>$\angle ace = \angle bce$</p> <p>$ac = bc$</p> <p>$\angle cae = \angle cbe$</p> <p>[ASA]</p>	<p>$ac = bc$</p> <p>$\angle ace = \angle bce$</p> <p>$ce = ce$</p> <p>[SAS]</p>	<p>$\angle aec = \angle ceb$ 90° 2</p> <p>$ac = bc$ 2</p> <p>$ce = ce$ 5</p> <p>[RHS] Not required</p>
--	--	---

Blunders (-3)

B1 Each step omitted

Attempts (2)

A1 One correct step

A2 States same shape or ASA or SAS or RHS only

A3 States triangles "fold" onto each other

Part (c)

20 Marks (5, 5, 5, 5)

Att 8(2, 2, 2,2)

$[ac]$ and $[bd]$ are diameters of a circle with centre o .
 L is a line touching the circle at the point b only.

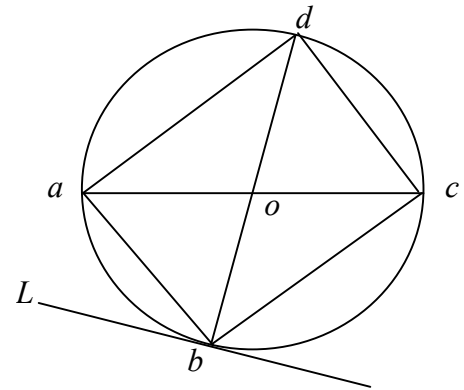

Part (c) (i)

5 marks

Att 2

(i) Name the image of Δaod under S_o , the central symmetry in the point o .

(i) $\Delta aod \rightarrow \Delta cob$

- * Accept Δcob with points in any order
- * Accept $a \rightarrow c, o \rightarrow o, d \rightarrow b$
- * Accept diagram with indication /shading (First use)

Blunders (-3)

- B1 Each point whose image is not found or incorrectly found
- B2 Image not a triangle eg a line or quadrilateral

Attempts (2 marks)

- A1 Shows some knowledge of central symmetry and stops
- A2 States that image is a Δ eg draws a triangle in the answers box
- A3 Image of one point found correctly eg in “ \rightarrow ” approach

Worthless (0)

- W1 Diagram reproduced without modification

Part (c) (ii)**5 marks****Att 2**

(ii) What is the name given to a line, such as the line L , that touches the circle at one point only?

(ii) Tangent or Tan

*Attempts (2 marks)*A1 Mentions 90°

A2 States "Is perpendicular to radius"

Part (c) (iii)**5 marks****Att 2**

(iii) Write down $|\angle abc|$, and give a reason for your answer.

(iii) $|\angle abc| = 90^\circ$ or $|\angle abc| = \text{Right Angle or Perpendicular Symbol}$
Reason: Angle in a semi circle / half circle or similar

Slips (-1)

S1 Correct answer without reason or incorrect reason

*Attempts (2 marks)*A1 States is equal to $|\angle adc|$ or any right angle in the circle

A2 States "Angle at centre = twice angle at circle standing on same arc" or similar

A3 180° on its own*Worthless (0)*

W1 Incorrect answer unless A3

(iv) Given that $|ad| = 4$, $|dc| = 3$, use the Theorem of Pythagoras to find $|ac|$.

	(iv)	$ ac ^2 = 3^2 + 4^2$	2
		$= 9 + 16$	2
		$= 25$	2
		$ ac = \sqrt{25}$	5
		$= 5$	

* Correct answer without work merits 2 marks 

Blunders (-3)

- B1 Incorrect Pythagoras' Theorem or incorrect application
- B2 Mathematical error eg $3^2 \neq 9$
- B3 Error in manipulation of equation

Slips (-1)

- S1 Numerical slips to a maximum of -3

Attempts (2 marks)

- A1 A correct step
- A2 States Pythagoras Theorem
- A3 Correctly identifies $|ac|$ as the hypotenuse in the answer box

Worthless (0)

- W1 Incorrect answer without work
- W2 $|ac| = 3 + 4 = 7$

QUESTION 5

Part (a)	10 marks	Att 4
Part (b)	25 marks	Att 8
Part (c)	15 marks	Att 7

Part (a) **10 marks (5, 5)** **Att (2, 2)**

(a) a is the point (1,2)

b is the point (-3,-2)

Plot the points a and b

- * No penalty if a and b are not labelled
- * No penalty if x and y axes reversed if consistent
- * (1,2) and (-3,-2) plotted 5 marks + 5 marks
or
- * (2,1) and (-2,-3) plotted 5 marks + 5marks

Slips (-1)

S1 One point correct but axes reversed for other point eg (2,1) and (-3,-2) plotted

Attempts (2 marks)

A1 Plots any incorrect point subject to S1

Part (b)

25 Marks (10,10,5)

Att 8 (3,3,2)

p is the point (2,1) and q is the point (4,3). Find each of the following:

Part (b)(i)

10 marks

Att 3

(i) the length of $[pq]$

	(i) the length of $[pq]$	$= \sqrt{(4-2)^2 + (3-1)^2}$ or	$= \sqrt{(2-4)^2 + (1-3)^2}$	3
		$= \sqrt{(2)^2 + (2)^2}$	$= \sqrt{(-2)^2 + (-2)^2}$	7
		$= \sqrt{4+4}$	$= \sqrt{4+4}$	9
		$= \sqrt{8}$	$= \sqrt{8}$	10

- * Correct answer without work merits 7 marks 
- * Accept correct use of Pythagoras
- * Blunders apply only once per section

Blunders (-3)

- B1 Incorrect formula e.g. $\sqrt{(x_2 - x_1)^2 - (y_2 - y_1)^2}$ or $\sqrt{(x_2 + x_1)^2 + (y_2 + y_1)^2}$
or omits \sqrt or omits squares
- B2 Incorrectly treats couples as (x_1, x_2) and (y_1, y_2)
- B3 Mathematical error e.g. sign rules
- B4 Two or more signs incorrect in substitution

Slips (-1)

- S1 Numerical slips to a maximum of -3
- S2 Error in one sign in $(x_2 - x_1)$ or $(y_2 - y_1)$ in formula
- S3 One incorrect substitution or sign when substituting

Misreadings (-1)

- M1 Uses points a and b from part (a) once only for section (b)

Attempts (3 marks)

- A1 Any relevant step eg subtraction shown
- A2 Points p and/or q plotted reasonably well for this part
- A3 States Theorem of Pythagoras and stops
- A4 Correct graphical solution –unless clearly Pythagoras
- A5 Identifies (x_1, y_1) and /or (x_2, y_2) outside the box – allow here only

Worthless (0)

- W1 Uses wrong formula e.g. midpoint formula

(ii)

the slope of pq

	(ii)	the slope of pq	$m = \frac{y_2 - y_1}{x_2 - x_1}$	0	$= \frac{\text{vertical}}{\text{horizontal}}$	3
		$= \frac{3-1}{4-2}$	or	$= \frac{1-3}{2-4}$	or vertical = 2 horizontal = 2	7
		$= \frac{2}{2}$ or 1		$= \frac{-2}{-2}$ or 1	$= \frac{2}{2}$ or 1	10

* Accept correct trigonometric method (i.e. $\tan \theta = \frac{2}{2}$)

Blunders (-3)

B1 Incorrect slope formula e.g. $\frac{x_2 - x_1}{y_2 - y_1}$ or $\frac{y_2 + y_1}{x_2 + x_1}$ or $\frac{y_2 - y_1}{x_1 - x_2}$ or $\frac{x_1 - y_1}{x_2 - y_2}$ or

$\frac{\text{horizontal}}{\text{vertical}}$ or $\tan \theta = \frac{\text{adjacent}}{\text{opposite}}$ and continues

B2 Incorrectly treats couples as (x_1, x_2) and (y_1, y_2) if not already penalised

e.g. $\frac{3-4}{1-2}$ or $\frac{4-3}{2-1}$.

B3 Mathematical error e.g. sign rules

B4 Gets the slope of op or oq correctly

B5 Error in more than one sign when substituting

Slips (-1)

S1 Numerical slips to a maximum of -3

S2 Error in one sign in slope formula e.g. $\frac{y_2 - y_1}{x_2 + x_1}$

S3 One incorrect substitution or sign when substituting

Attempts (3 marks)

A1 $\tan \theta = \frac{\text{opposite}}{\text{adjacent}}$ or $m = \frac{\text{vertical}}{\text{horizontal}}$ and stops

A2 Some correct substitution into formula with $x_2 - x_1$ and/or $y_2 - y_1$

A3 Points p and/or q plotted reasonably well for this part

A4 Identifies (x_1, y_1) and/or (x_2, y_2) in this part

Worthless (0)

W1 Uses wrong formula e.g. midpoint formula

W2 States given formula, only

(iii)

The equation of pq 

(iii)

$$y - 1 = \frac{1}{5}(x - 2) \quad \text{or} \quad y - 3 = \frac{1}{5}(x - 4)$$

- * Correct answer without work merits 2 marks
- * Accept candidate's slope from previous section

Blunders (-3)

- B1 Incorrect formula e.g. $y + y_1 = m(x + x_1)$ or $x - x_1 = m(y - y_1)$
- B2 Switches x and y e.g. $y - 4 = 1(x - 3)$
- B3 Mathematical error
- B4 $y = x + c$ and stops
- B5 Uses a point other than (2,1) or (4, 3) e.g. (0,0)
- B6 $m \neq 1$

Slips (-1)

- S1 Numerical slips to a maximum of -3
- S2 Error in one sign in formula
- S3 One incorrect substitution or sign when substituting

Attempts (2 marks)

- A1 Writes $m = 1$ and stops
- A2 States $y = mx \pm c$ and stops
- A3 $3 - 1 = 1(4 - 2)$ substitutes both points

Note: $1 - y_1 = 1(2 - x_1)$ merits full marks

Part (c)

15 marks (5,5,5)

Att 6 (2,2,2)

L is the line $2x + 3y - 10 = 0$.
 L cuts the x - axis at the point c .

Part (c) (i)

5 marks

Att 2

(i) By letting $y = 0$, find the co-ordinates of the point c .

 (i)

$$\begin{aligned} 2x + 3y - 10 &= 0 \\ 2x + 3(0) - 10 &= 0 & 2 \\ 2x - 10 &= 0 \\ 2x &= 10 & 2 \\ x &= \frac{10}{2} = 5 & 5 \end{aligned}$$

4(marks)

- * Correct answer without work merits 2 marks 
- * Accept answer given as $x = 5$ with work shown

Blunders (-3)

- B1 Substitutes $x = 0$ and continues
- B2 Mathematical error
- B3 Incorrect substitution and continues

Slips (-1)

- S1 Numerical slips to a maximum of -3
- S2 $3(0) = 3$
- S3 Stops at $\frac{10}{2}$ with work

Attempts (2 marks)

- A1 Substitutes $y = 0$ and stops
- A2 Any correct manipulation of equation and stops

Worthless (0)

- W1 Incorrect answer without work

Part (c) (ii)

5 marks

Att 2

(ii) Show that the point (8, -2) is on the line L .



(ii)

L

$$2x + 3y - 10 = 0$$

$$2(8) + 3(-2) - 10 = 0 \quad 2$$

$$16 - 6 - 10 = 0 \quad 2$$

$$10 - 10 = 0 \quad 5$$

* Correct answer without work merits 2 marks

Blunders (-3)

B1 Incorrect substitution and continues eg switches x and y

B2 Mathematical error

Slips (-1)

S1 Numerical slips to a maximum of -3

Attempts (2 marks)

A1 Substitutes one correct value and stops

A2 Identifies (8, -2) as (x, y) $x=8$ and/or $y=-2$ or plots point

A3 Any correct transposition of equation and stops eg $2x + 3y = 10$

(iii) The point $(k, 6)$ is on the line L . Find the value of k .



(iii)

$$L \quad 2x + 3y - 10 = 0$$

$$2(k) + 3(6) - 10 = 0 \quad 2$$

$$2k + 18 - 10 = 0 \quad 2$$

$$2k = -8 \quad 2$$

$$k = \frac{-8}{2} = -4 \quad 5$$

(4marks)

* Correct answer without work merits 2 marks

Blunders (-3)

- B1 Substitutes $x = 6$ and $y = k$ and continues
- B2 Mathematical error
- B3 Incorrect transposition eg $k = -8-2$

Slips (-1)

- S1 Numerical slips to a maximum of -3
- S2 $\frac{-8}{2}$ with work and stops

Misreadings (-1)

- M1 Reads as $2x + 3y + 10 = 0$ and continues

Attempts (2 marks)

- A1 Substitutes one value correctly and stops
- A2 States $x = k$ and/or $y = 6$ and stops or plots $(?, 6)$
- A3 Some statement similar to “substituting in will satisfy the equation”
- A4 Use of arbitrary value e.g. $x = 0$ or $y = 0$ with some correct work
- A5 Any correct transposition of equation, in this part, and stops eg $2x + 3y = 10$

Worthless (0)

- W1 Incorrect answer without work

QUESTION 6

Part (a)	15 marks	Att 5
Part (b)	20 marks	Att 7
Part (c)	15 marks	Att 5

Part (a)

15 marks (10, 5)

Att (3, 2)

The right - angled triangle abc has measurements as shown.

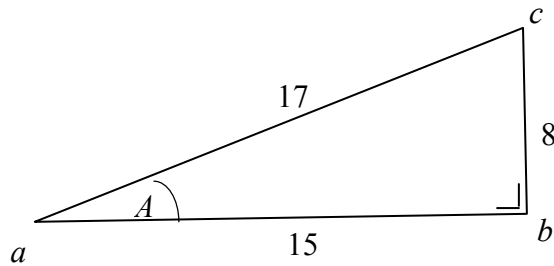

Part (a) (i)

10 marks

Att 3

(i) Write down the length of the side adjacent to the angle A

(i) Length of the side adjacent to the angle $A = 15$

* Indicates 15 only on diagram, accept “a” or “adj”, for 10 marks

Blunders (-3)

B1 Writes one of the other sides

Attempts (3marks)

A1 Any mention of a correct trigonometric ratio

A2 Writes $[ab]$ or $[ba]$

Part (a) (ii)

5 marks

Att 2

(ii) Write down the value of $\cos A$, as a fraction

(ii) $\cos A = \frac{15}{17}$

* Accept consistent error from (i)

* Accept $\cos \frac{15}{17}$ for full marks

Blunders (-3)

B1 Incorrect or inverted ratio e.g. $\cos A = \frac{17}{15}$

B2 Gets cos of top angle (check is not consistent error from (i))

Slips (-1)

S1 Answer = 0.8823 (answer not fraction)

Attempts (2 marks)

A1 Any correct trigonometric ratio written down in answer box

A2 Only gives answer = 28° exactly or rounded to 28° for this part

A3 Only gives answer = 0.999881422 ie $\cos(15/17)$

Part (b)**20 Marks (5, 10, 5)****Att 7 (2, 3, 2)**

In the right angled triangle pqr .
 $|pq| = 12$ and $|\angle pqr| = 37^\circ$. Let $x = |pr|$.

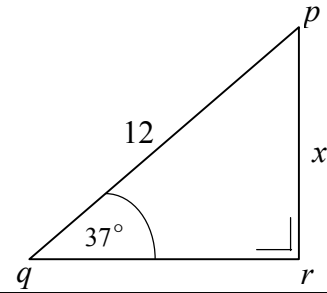
**Part (b) (i)****5 marks****Att 2**

(i) Using the diagram, write down the value of $\sin 37^\circ$ as a fraction.

(i) $\sin 37^\circ = \frac{x}{12}$

* Accept $\sin \frac{x}{12}$ for full marks

* Accept $\sin 37^\circ = \frac{|pr|}{|pq|} = \frac{x}{|pq|}$ Modulus not required

Blunders (-3)

B1 Incorrect or inverted ratio eg $\frac{x}{|qr|}$

Slips (-1)

S1 21 for 12

Attempts (2 marks)

A1 Any correct trigonometric ratio written down

A2 Correctly marks hypotenuse or opposite or adjacent on diagram and stops –first part of question

A3 0.6018 or 0.6 or $\frac{6}{10}$

Worthless (0)

W1 Incorrect answer unless attempt mark applies

Part (b) (iii)

5 marks

Att 2

(iii) Hence find x , the value of $|pr|$

	(iii)	$\frac{x}{12}$	$= 0.6$	2
		x	$= 12 \times 0.6$	2
			$= 7.2$	5

- * Correct answer without work merits 2 marks 
- * Accept candidate's answers from parts (i) and (ii)

Blunders (-3)

- B1 Error in forming equation eg $\frac{12}{x} = 0.6$ and continues
- B2 Error in transposing equation
- B3 Error in decimal point
- B4 Mathematical error

Slips (-1)

- S1 Numerical slips to a maximum of -3
- S2 Gives answer as 7.0 only with work shown

Attempts (2 marks)

- A1 Correct scale diagram
- A2 First step of scheme and stops
- A3 Any correct step

Worthless (0)

- W1 Incorrect answer without work
- W2 $x = 4$ cm (measured from examination paper)

- (ii) Hence, calculate $|ab|$, the width of the river.
Give your answer correct to the nearest metre.

 (ii)	$\frac{ ab }{ ac } = \tan 25^\circ$	or	$\frac{ ac }{ ab } = \tan 65^\circ$	2
	$\frac{ ab }{45} = 0.4663$		$\frac{45}{ ab } = 2.1445$	2
	$ ab = 0.4663 \times 45$		$ ab = \frac{45}{2.1445}$	2
	$= 20.98$		$= 20.98$	4
	$= 21 \text{ m}$		$= 21 \text{ m}$	5

- * Correct answer without work merits 2 marks 
* Accept candidate's answer from part (i)

Blunders (-3)

- B1 Incorrect trigonometric ratio
B2 No decimal point or misplaced decimal point
B3 Uses radian or grad mode on calculator
B4 Mathematical error
B5 Incorrect transposition

	Rad	Grad
Tan 25°	-0.1335	0.4142
Tan 65°	-1.4700	1.63185

Slips (-1)

- S1 Numerical slips to a maximum of -3
S2 Fails to round off or rounds off incorrectly
S3 Obvious slip in reading tables or calculator
S4 Calculates $|bc|$ correctly

Attempts (2 marks)

- A1 Any correct trigonometric ratio written down
A2 Some use of Sin/Cos/Tan
A3 Finds the third angle of the triangle and stops - must be in answer box
A4 Correct scale diagram
A5 Any relevant step

Worthless (0)

- W1 Incorrect answer without work
W2 $|ab| = 4.5 \text{ cm}$, measured off examination paper.